

## RPHD/RPHS HYDRAULIC ACTUATORS

### RACK & PINION DESIGN

Double-acting and spring return hydraulic quarter-turn actuators. For on-off and modulating control of valves in heavy duty service with models for output torques to 2,600 Nm.

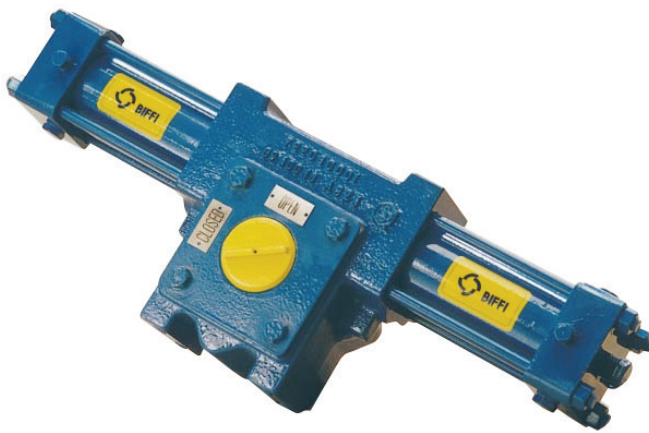

#### FEATURES

- Totally enclosed, weatherproof housing in high strength nodular cast iron, suitable for use in hostile environments.
- Integral vent valve prevents accidental pressurisation.
- Compact rack and pinion design provides simple construction.
- RPHD double cylinder design allows different torques in opening and closing.
- Precise angular stroke adjustment between 80° and 100°.
- Electroless nickel plated and polished cylinder for corrosion resistance and minimal friction.
- Low hysteresis and high sensitivity piston seals prevent sticking problems.
- Bushings in sintered bronze charged with PTFE for minimal friction and long life.
- Fully encapsulated RPHS spring module ensures personnel safety and simplifies assembly.
- Cast steel option available.

#### GENERAL APPLICATION

RPHD and RPHS are hydraulic high-pressure actuators suitable for any low-torque quarter turn application such as ball, plug, butterfly valves or dampers.

#### APPROVALS

Safety Integrity Level:  
(IEC 61508-1÷7:2010): SIL 3  
Area Classification:  
(ATEX): II 2GD 135°C (T4)  
Enclosure Standards:  
(IEC 60529): IP67M  
(ANSI/NEMA 250): NEMA 4, 4X, 6  
Pressure Equipment Directive:  
PED 97/23/EC  
Machinery Directive:  
2006/42/EC

#### TECHNICAL DATA

Supply pressure:	220 barg
Supply medium:	Hydraulic oil or fire-resistant fluid
Ambient temperature:	-30°C to +100°C
Output torques:	up to 2600 Nm

# RPHD/RPHS HYDRAULIC ACTUATORS

## RACK & PINION DESIGN

### RPHS - SPRING RETURN

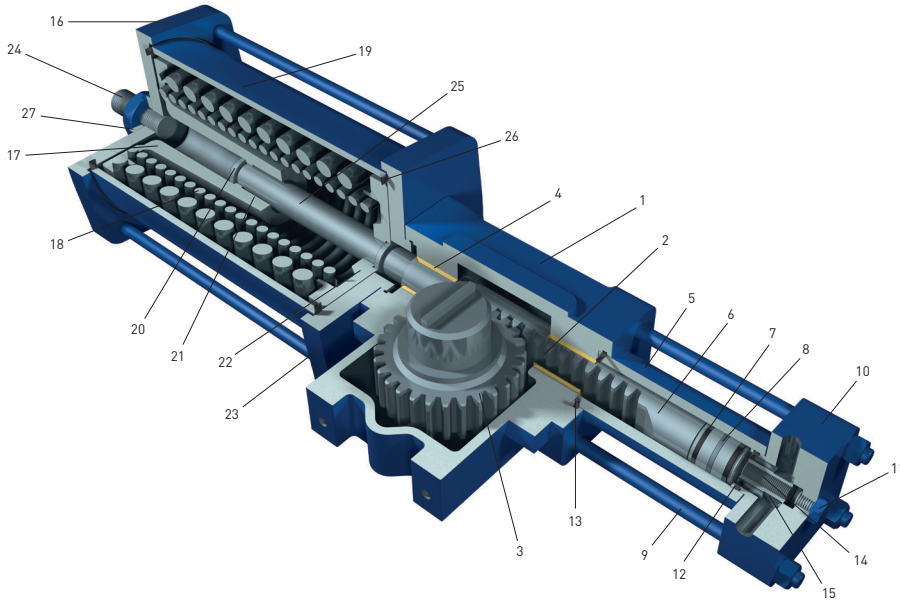

### RPHD - DOUBLE ACTING

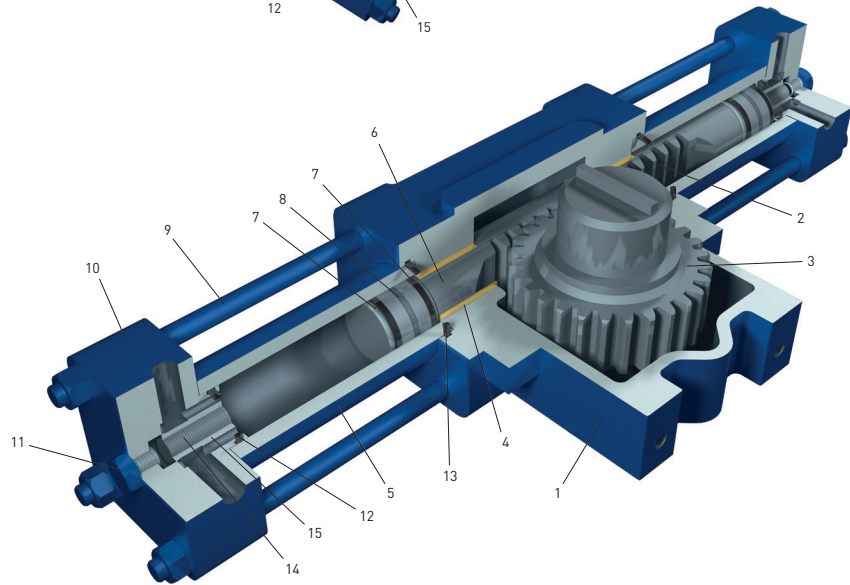

### MATERIALS

Part	Material	Part	Material
1 Housing	Nodular cast iron	15 Friction bar	Nylon
2 Rack	Alloy Steel	16 End spring flange	Carbon steel
3 Pinion	Alloy Steel	17 Spring guide flange	Nodular cast iron
4 Bushing	Iron + Bronze + PTFE	18 Spring	Alloy steel
5 Cylinder tube	Nickel plated carbon steel	19 Spring cartridge tube	Carbon steel
6 Piston	Carbon Steel	20 Retainer ring	Stainless steel
7 Guide sliding piston ring	PTFE + graphite	21 Bushing	Iron + bronze + PTFE
8 Piston seal ring	PTFE + graphite + NBR	22 Spring thrust flange	Carbon steel
9 Tie rod	Alloy steel	23 Head spring flange	Carbon steel
10 End flange	Carbon steel	24 Adjusting screw	Carbon steel
11 Plug	Stainless steel	25 Spring guide rod	Alloy steel
12 O-ring	NBR	26 Gasket	NBR
13 O-ring	NBR	27 Washer	Stainless steel
14 Stop setting screw	Carbon steel		

# RPHS/RPHD HYDRAULIC ACTUATORS

## OUTPUT TORQUES (Nm)

### RPHD DOUBLE ACTING HYDRAULIC ACTUATOR

Model	Operating supply pressure (bar g)										MOP
	60	80	104	120	140	160	180	200	207	220	
10-032	126	169	219	253	295	337	379	421	436	463	227
20-040	197	263	342	395	461	527	592	658	681	724	224
20-050	309	411	535	617	720						143
40-045	467	622	809	933	1089	1244	1400	1555	1609	1711	225
40-055	697	929	1208	1394	1626						150
40-065	973	1298	1687								107
80-055	697	929	1208	1394	1626	1858	2091	2323	2404	2555	223
80-065	973	1298	1687	1947	2271	2596					160

### RPHS SPRING RETURN HYDRAULIC ACTUATOR

Model	Operating supply pressure (bar g)																						
				60		80		104		120		140		160		180		200		207		220	
	MOP	BTC	ETC	BTO	ETO	BTO	ETO	BTO	ETO	BTO	ETO	BTO	ETO	BTO	ETO	BTO	ETO	BTO	ETO	BTO	ETO	BTO	ETO
10-032-SS1-CL	220	128	93			65	26	115	76	149	110	191	152	233	194	276	236	318	278	332	293	360	321
10-032-SS1I-CL	220	68	53	67	50	109	92	159	143	193	176	235	218	277	261	319	303	362	345	376	360	404	387
20-040-SS2-CL	220	294	222					95	16	148	69	214	135	280	201	346	266	411	332	434	355	477	398
20-040-SS2E-CL	220	161	126	57	18	123	84	202	163	254	216	320	281	386	347	452	413	518	479	541	502	584	545
20-040-SS2I-CL	220	129	93	93	54	159	120	238	199	291	252	356	318	422	383	488	449	554	515	577	538	620	581
20-050-SS2-CL	180	294	222			164	85	288	209	370	291	473	394	576	497	679	600						
20-050-SS2E-CL	160	161	126	168	129	271	232	394	355	477	438	579	541	682	643								
20-050-SS2I-CL	160	129	93	204	165	307	268	430	392	513	474	616	577	718	680								
40-045-SS4-CL	220	618	451					309	125	433	249	589	405	744	560	900	716	1055	871	1110	926	1211	1027
40-045-SS4E-CL	220	471	332			254	100	441	287	565	411	721	567	876	722	1032	878	1187	1033	1241	1088	1343	1189
40-055-SS4-CL	180	618	451	197	13	429	245	708	524	894	710	1126	942	1358	1175	1591	1407						
40-055-SS4E-CL	180	471	332	329	175	561	407	840	686	1026	872	1258	1104	1490	1336	1723	1569						
40-065-SS4-CL	120	618	451	473	290	798	614	1187	1003	1447	1263												
40-065-SS4E-CL	120	471	332	605	451	930	776	1319	1165	1579	1425												
80-055-SS5-CL	220	1272	940									586	219	818	451	1051	684	1283	916	1364	997	1515	1148
80-055-SS5E-CL	220	776	588			278	71	557	350	743	536	975	768	1207	1000	1440	1232	1672	1465	1753	1546	1904	1697
80-055-SS5I-CL	220	457	318	345	191	577	423	856	702	1042	888	1274	1120	1506	1352	1738	1585	1971	1817	2052	1898	2203	2049
80-065-SS5-CL	220	1272	940					647	280	907	540	1231	864	1556	1189	1880	1513	2205	1837	2318	1951	2529	2162
80-065-SS5E-CL	200	776	588	322	115	647	440	1036	829	1296	1088	1620	1413	1945	1737	2269	2062	2594	2386				
80-065-SS5I-CL	180	457	318	621	467	946	792	1335	1181	1594	1441	1919	1765	2243	2089	2568	2414						

#### NOTES

MOP: Maximum Operating Pressure

BTC: Break To Close

ETC: End To Close

BTO: Break To Open

ETO: End To Open

# RPHD DOUBLE ACTING HYDRAULIC ACTUATOR

## OVERALL DIMENSIONS

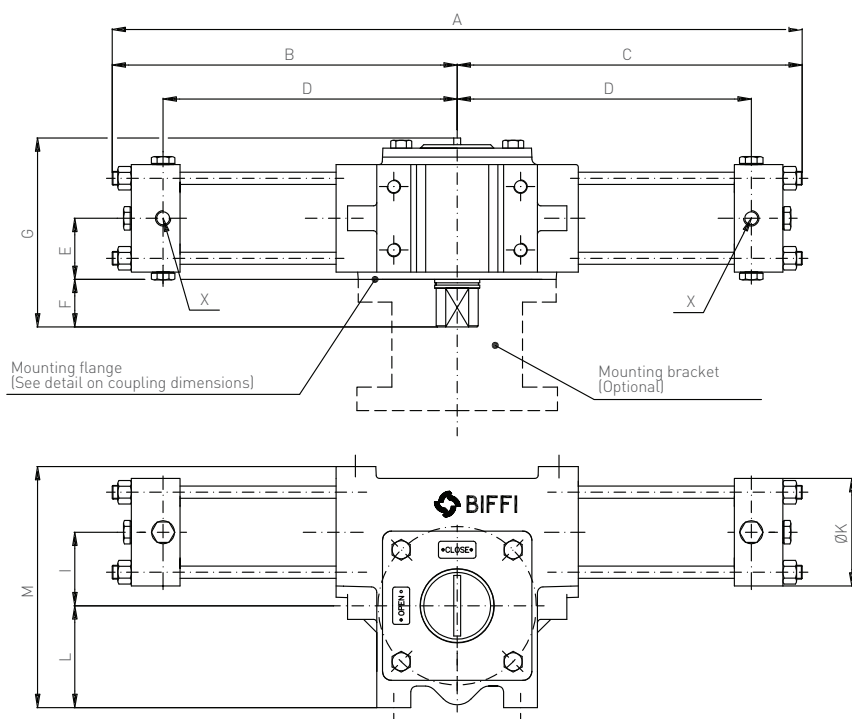

### DIMENSIONS (mm)

Model	A	B	C	D	E	F	G	ØK	I	L	M	X	Weight (kg)
10-032	458	229	229	188	47	33	144	80	36	70	161	2 x 1/4 NPT	16
20-040	457	229	229	189	47	45	155	80	36	70	161	2 x 1/4 NPT	19
20-050	457	229	229	189	47	45	155	80	36	70	161	2 x 1/4 NPT	20
40-045	610	305	305	260	51	45	167	95	65	90	213	2 x 1/4 NPT	32
40-055	610	305	305	260	51	45	167	95	65	90	213	2 x 1/4 NPT	34
40-065	610	305	305	260	51	45	167	95	65	90	213	2 x 1/4 NPT	37
80-055	620	310	310	260	51	58	180	95	65	90	213	2 x 1/4 NPT	37
80-065	620	310	310	260	51	58	180	95	58	65	213	2 x 1/4 NPT	39

# RPHS SPRING RETURN HYDRAULIC ACTUATOR

## OVERALL DIMENSIONS- SPRING TO OPEN

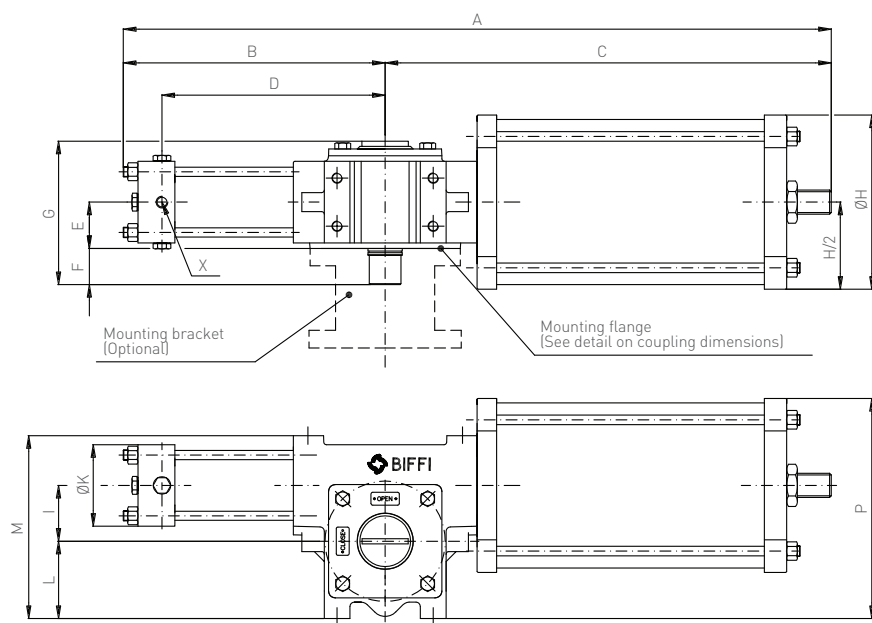

### DIMENSIONS (mm)

Model	A	B	C	D	E	F	G	ØH	ØK	I	L	M	P	X	Weight (kg)
10-032-SS1-OP	592	234	357	201	50	30	143	112	80	36	71	163	163	1/4" NPT	28
20-040-SS2-OP	584	229	355	189	50	27	152	149	80	36	70	161	181	1/4" NPT	36
20-050-SS2-OP	584	229	355	189	50	27	152	149	80	36	70	161	181	1/4" NPT	40
40-045-SS4-OP	809	305	504	260	54	44	195	195	95	65	90	213	252	1/4" NPT	64
40-055-SS4-OP	809	305	504	260	54	44	195	195	95	65	90	213	252	1/4" NPT	76
40-065-SS4-OP	809	305	504	260	54	44	195	195	95	65	90	213	252	1/4" NPT	80
80-055-SS5-OP	809	305	504	260	54	44	195	195	95	65	90	213	280	1/4" NPT	80
80-065-SS5-OP	820	310	510	260	54	71	250	250	95	65	90	213	280	1/4" NPT	90

# RPHS SPRING RETURN HYDRAULIC ACTUATOR

## OVERALL DIMENSIONS- SPRING TO CLOSE

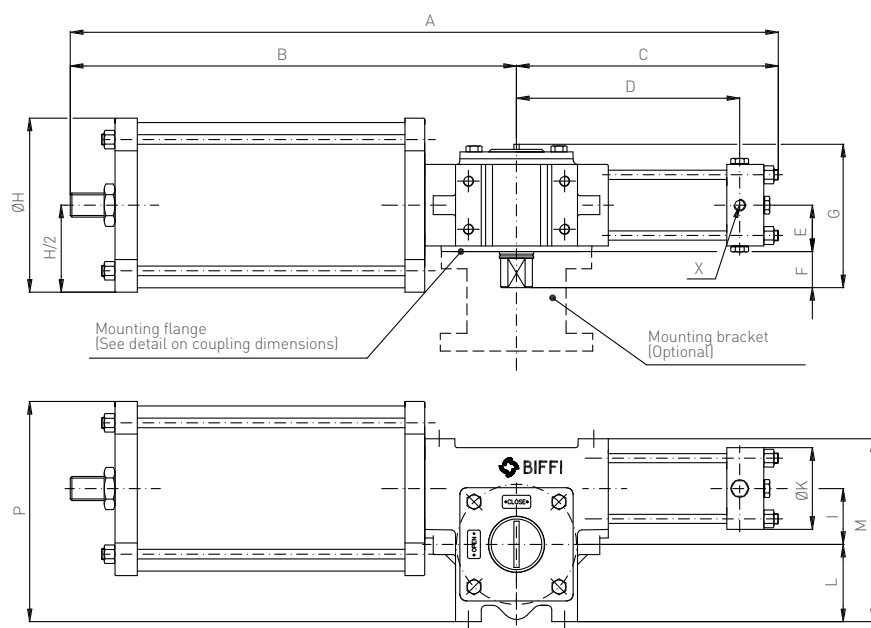

### DIMENSIONS (mm)

Model	A	B	C	D	E	F	G	ØH	ØK	I	L	M	P	X	Weight (kg)
10-032-SS1-CL	592	357	234	201	50	30	143	112	80	36	71	163	163	1/4" NPT	28
20-040-SS2-CL	584	355	229	189	50	27	152	149	80	36	70	161	181	1/4" NPT	36
20-050-SS2-CL	584	355	229	189	50	27	152	149	80	36	70	161	181	1/4" NPT	40
40-045-SS4-CL	809	504	305	260	54	44	195	195	95	65	90	213	252	1/4" NPT	64
40-055-SS4-CL	809	504	305	260	54	44	195	195	95	65	90	213	252	1/4" NPT	76
40-065-SS4-CL	809	504	305	260	54	44	195	195	95	65	90	213	252	1/4" NPT	80
80-055-SS5-CL	820	510	310	260	54	71	250	250	95	65	90	213	280	1/4" NPT	90
80-065-SS5-CL	820	510	310	260	54	71	250	250	95	65	90	213	280	1/4" NPT	92

# RPHS/RPHD HYDRAULIC ACTUATORS

## MOUNTING DIMENSIONS - COUPLINGS

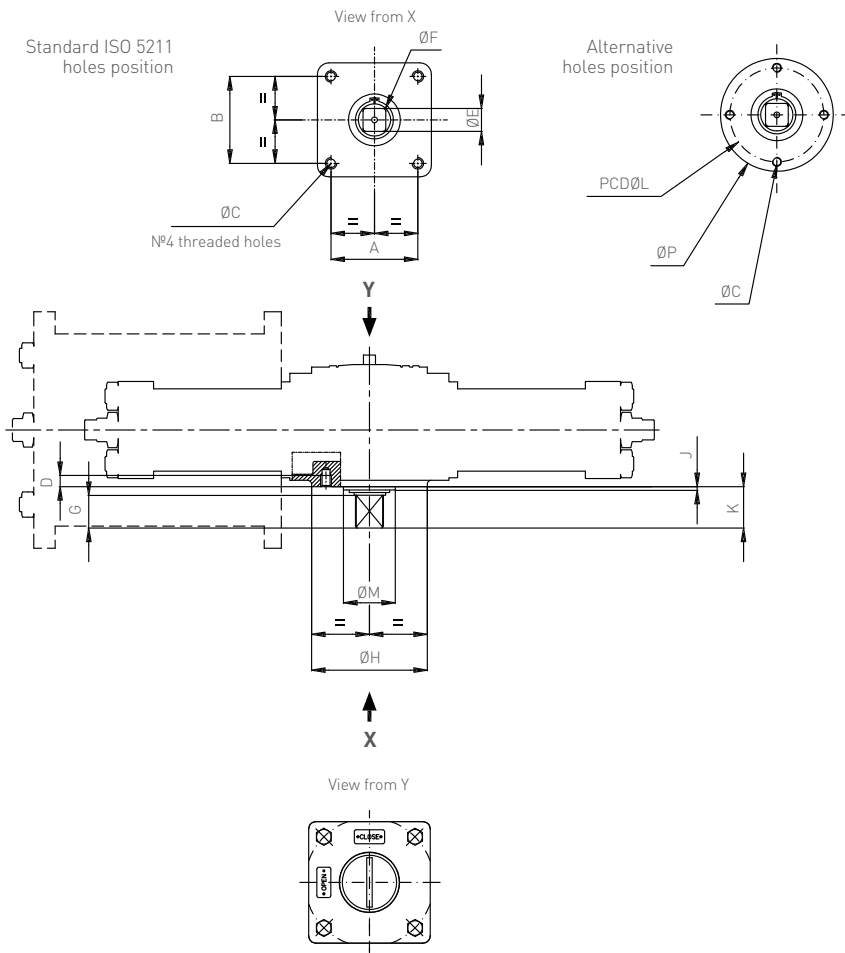

Actuator shown in closed position

### DIMENSIONS (mm)

Actuator model	A ± 0.2	B ± 0.2	ØC	D	ØE	ØF	G	ØH	K	J	ØL	ØM	ØP
RPHD - 10	49.5	49.5	M8	10	16	21	23	66	30	3	70	40	90
RPHS - 10	49.5	49.5	M8	10	16	21	23	66	30	3	70	40	90
RPHD - 20	72.1	72.1	M10	12	22	29	25	92	32	3	102	50	125
RPHS - 20	72.1	72.1	M10	12	22	29	25	92	32	3	102	50	125
RPHD - 40	88.4	88.4	M12	15	28	37	34	112	42	3	125	60	150
RPHS - 40	88.4	88.4	M12	15	28	37	34	112	42	3	125	60	150
RPHD - 80	99	99	M16	23	37	49	45	132	55	3	140	75	175
RPHS - 80	99	99	M16	23	37	49	45	132	55	3	140	75	175

# RPHD DOUBLE ACTING HYDRAULIC ACTUATOR

## MOUNTING DIMENSIONS - ACCESSORIES

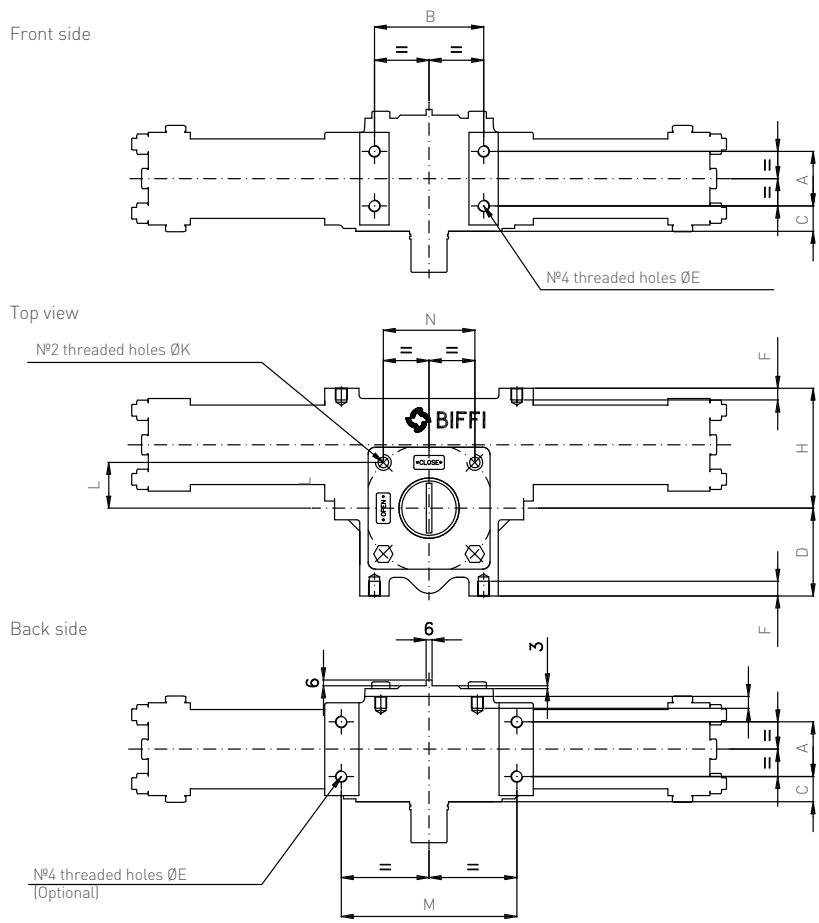

Actuator shown in closed position

### DIMENSIONS (mm)

Actuator model	A ± 0.2	B ± 0.2	C	D	ØE	F	G	H	ØK	J	L	M	N
RPHD - 10	50	104	21	70.5	M12	12	2	90.5	M8	15	36	130	72
RPHD - 20	50	104	21	70.5	M12	12	24	90.5	M8	15	36	130	72
RPHD - 40	56	112	26	90	M12	12	40	123	M10	23	49.5	180	99
RPHD - 80	56	112	26	90	M12	12	67	123	M10	23	49.5	180	99

# RPHS SPRING RETURN HYDRAULIC ACTUATOR

## MOUNTING DIMENSIONS - ACCESSORIES

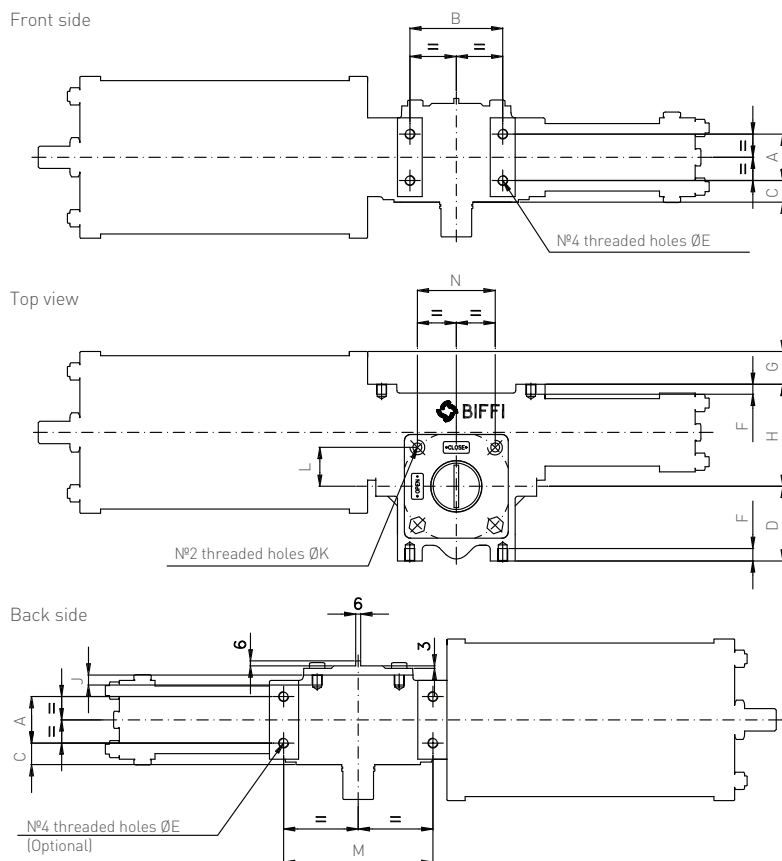

Actuator shown in closed position

### DIMENSIONS (mm)

Actuator model	A ± 0.2	B ± 0.2	C	D	ØE	F	G	H	ØK	J	L	M	N
RPHS - 10	50	104	21	70.5	M12	12	2	90.5	M8	15	36	130	72
RPHS - 20	50	104	21	70.5	M12	12	24	90.5	M8	15	36	130	72
RPHS - 40	56	112	26	90	M12	12	40	123	M10	23	49.5	180	99
RPHS - 80	56	112	26	90	M12	12	67	123	M10	23	49.5	180	99

# RPHS SPRING RETURN HYDRAULIC ACTUATOR

## MODEL DECODING

---

### RP DOUBLE ACTING HYDRAULIC ACTUATORS

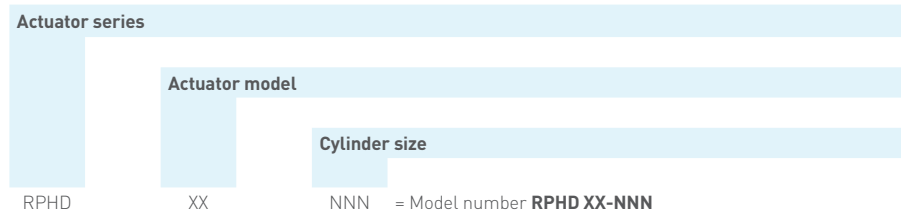

### RP SINGLE ACTING HYDRAULIC ACTUATORS

