



KTM HINDLE ULTRA-SEAL BALL VALVES

OPERATION, INSTALLATION AND MAINTENANCE INSTRUCTIONS

Before installation these instructions must be fully read and understood

1 STORAGE/SELECTION/PROTECTION

Ultra-Seal, free floating ball valves offer superior sealing downstream and to atmosphere, in both reduced and full bore designs.

Storage

When valves are to be stored for some time before being fitted, storage should be in the original delivery crates with any waterproof lining and/or desiccant remaining in place. Storage should be off the ground in a clean, dry, indoor area. If storage is for a period exceeding six months the desiccant bags (if supplied) should be changed at this interval.

Selection

Ensure that the materials of construction and pressure/temperature limits shown on the valve identification label, are suitable for the process fluid and conditions. If in doubt, contact the factory.

Protection

KTM Hindle ball valves are delivered with protection according to customer's specification, or in accordance with the Quality Assurance Manual, to protect the valve seats and ball from damage. Wrapping and/or covers should be left in place until immediately before fitting to the pipe.

2 INSTALLATION

1. Remove protective covers from valve faces.
2. Ensure that mating flanges and gaskets are clean and undamaged.
3. Fit the valve into pipework tightening the flange bolts in a diagonal pattern.

NOTE

- a. KTM Hindle Ultra-Seal ball valves are bi-directional as standard and may be fitted in either direction.
- b. Installation may be carried out with stem displaced through any angle permitted by the bolting.
- c. For certain services (chlorine etc.) the valves are designed to be uni-directional, in which case the valve body will be labeled 'High pressure side' or 'Flow direction'.

WARNING

For safety reasons, it is important to take the following precautions before you start work on the valve:

1. *Personnel making any adjustments to the valves should utilize equipment and clothing normally used to work with the process where the valve is installed.*
2. *The line must be depressurized before installing the valve.*
3. *Handling of all valves, operators and actuators must be carried out by personnel trained in all aspects of manual and mechanical handling techniques.*
4. *Valves on liquid service, which may be subjected to rapidly increasing temperature in the closed position, will need a positive means for relieving excessive cavity pressures. For further information contact KTM Hindle.*

3 ROUTINE MAINTENANCE AND OPERATIONAL SPARES

Scope

Standard Ultra-Seal ball valves both manual and actuated. For special service designs, typically cryogenic and fugitive emissions see separate instructions.

Routine maintenance

No routine maintenance is required other than periodic inspection to ensure satisfactory operation and sealing. Any sign of leakage from the gland packing should be addressed immediately by tightening the gland screws gradually and evenly. If no further adjustment is possible the packing should be renewed by following the instructions in paragraph 4.1.

Spare parts

KTM Hindle valves are identified by a figure number, which is stamped on the identification plate, located on the valve body flange. This reference should be quoted in respect of any after sales queries, spare parts or repair enquiries/orders.

Two year operational spares

Soft goods kits only, are recommended for the first two years of operation, as follows:

- 2 PTFE seat rings
- 1 sleeve seal
- 1 set of gland packing

Our technical sales department on request will recommend the number of kits required. Metallic components are not normally replaced in the initial 2-year period. Any damage to metallic components such as stem or ball may necessitate replacement. Consult technical sales department for advice.

KTM HINDLE ULTRA-SEAL BALL VALVES

OPERATION, INSTALLATION AND MAINTENANCE INSTRUCTIONS

4 MAINTENANCE

CAUTION

Before attempting any maintenance, ensure the system has been fully depressurized and if necessary, drained of any dangerous fluids. The valve being removed should be operated at least once and left in the half open position before removal.

Before disassembling the valve ensure the valve has been decontaminated correctly from any harmful gasses or fluids and that it is within a safe temperature range for handling.

Personnel making any adjustments to the valves should utilize equipment and clothing normally used to work with the process where the valve is installed.

Handling of all valves, operators and actuators must be carried out by personnel trained in all aspects of manual and mechanical handling techniques.

Parts identification

The illustrations on page 3 and 4 show the parts comprising the Series 110 and Series 200 valves.

4.1 Replacement of valve components

If no further adjustment of the gland is possible and stem leakage is still evident or seat leakage is suspected, the valve will need to be removed from the line in order for new seats/seals to be fitted.

After removal of the valve, place the valve on a workbench with the sleeve end uppermost and adopt the following procedure to remove/replace the seats/seals:

Removal

Series 110 valves

1. Remove sleeve (using sleeve extraction tool), sleeve seal and upper seat ring.
2. Remove ball.
3. Remove bottom seat ring.
4. Remove the operator (lever, gearbox, actuator) in accordance with instructions in paragraph 4.2.
5. Remove gland screws.
6. Remove stem nut and stop plate.
7. Remove gland spring and wiper seal.
8. Remove stem and thrust seal.
9. Remove graphite fire-seal/s.

Series 200 valves (Reduced bore)

1. Complete steps 1 - 4 of the above - Series 110 (torque multiplier will be needed for removal of sleeve on larger valves).
5. Remove stop plate.
6. Remove gland screws and gland.
7. Remove cover screws and cover.
8. Remove stem and thrust seal.
9. Remove cover gasket, gland spring, header, chevrons and spreader.

Series 200 valves (Full bore - 2 piece ball)

1. Remove the operator (as described below).
2. Complete sections 5 - 7 as above (Series 200 red.)
3. Pull stem out as far as possible, in order to disengage stem from ball.
4. Remove sleeve, sleeve seal and upper seat ring.
5. Remove ball as follows:
Rotate the ball assembly inside the body, so that the locking ring is facing the valve end where the sleeve has been removed.
 - 5.1. Drive off the locking ring (as shown in Figure 1).
 - 5.2. Remove each half of the ball from the valve using 'T-bars'. The half without the bottom ball key must be removed first and when re-assembling insert last (Figure 2).
6. Remove bottom seat ring.
7. Remove stem from valve bore.

Refitting is the reversal of removal

Before refitting, ensure all sealing and metallic surfaces in seat pockets and stem seal bores are free from damage/corrosion. Minor defects can be polished using abrasive cloth. If major defects are found contact KTM Hindle's service department for possible repair or component exchange.

4.2 Removal and refitting of operator

Removal

Handlever/T'-bar

1. Remove the lever screw and lever washer.
2. Remove the handlever/T'-bar.

Refitting is the reversal of removal.

Removal

Gearbox/actuator

1. Remove mounting bracket screws.
2. Remove mounting bracket and gearbox/actuator.
3. Remove drive adaptor screw (Series 110 only).
4. Remove drive adaptor.

Refitting is the reversal of removal.

4.3 Setting of travel stops on gearbox and actuated operators

[See Figure 3 for diagram of travel stop positions]

(a) With valve out of pipeline

1. Close valve fully
2. Remove plastic indicator cover from top of gearbox
3. Release closed stop screw.
4. Align diamond shaped drive points parallel to valve bore (Figure 4).
5. Tighten closed stop screw, allowing for backlash between adaptor and stem.

6. Hold stop screw in position with Allen key and tighten locking nut.
7. Open valve fully.
8. Visibly check that ball port is aligned with valve bore. If incorrect follow rest of procedure.
9. Release open stop screw.
10. Adjust ball position using handwheel until valve is porting correctly.
11. Tighten open stop screw and lock off with locknut.

(b) With valve in pipeline

Adopt steps 1 - 6 as above for open and closed positions.

NOTE

For the setting of stops on actuators, see separate instructions.

KTM HINDLE ULTRA-SEAL BALL VALVES

OPERATION, INSTALLATION AND MAINTENANCE INSTRUCTIONS

PARTS LIST

Item	Component
1	Body
3	Sleeve
7	Ball
8	Shaft
20	Gland
22	Shaft anti-static ball
23	Shaft anti-static spring
24	Body seat
25	Sleeve seat
29	Gland spring
30	Shaft nut
55	Gland screw
65	Shaft primary seal
71	Sleeve seal
75	Shaft fire seal
78	Wiper seal
90	Handlever
91	Handlever washer
92	Handlever screw
93	Stop screw
94	Stop collar
95	Stop plate

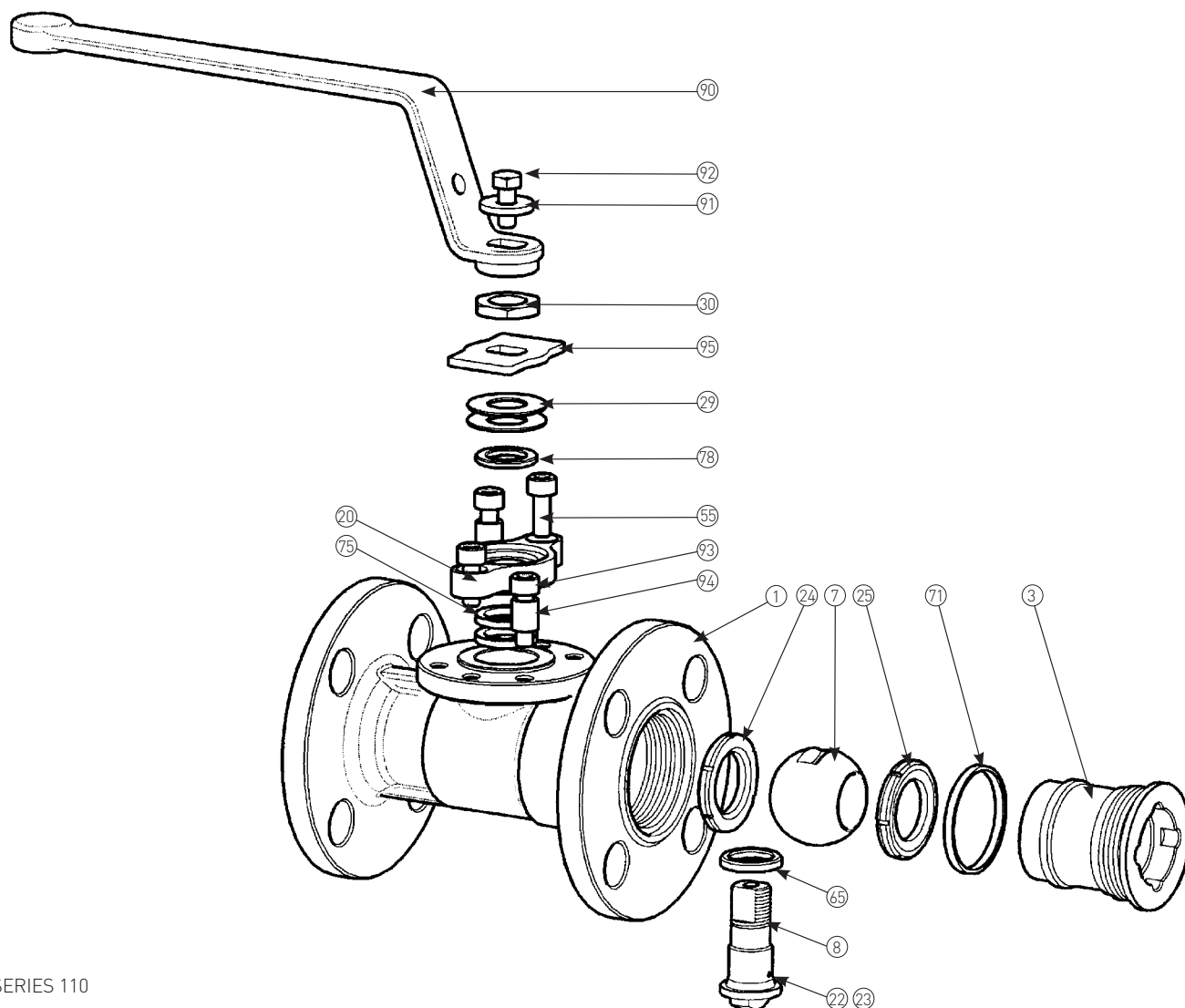

SERIES 110

KTM HINDLE ULTRA-SEAL BALL VALVES

OPERATION, INSTALLATION AND MAINTENANCE INSTRUCTIONS

PARTS LIST

Item	Component	Item	Component
1	Body	19	Thrust seal
2a	Ball half	20	Sleeve seal
2b	Ball locking ring	21	Seat ring
2c	Ball key	22	Chevron ring
3	Stem	23	Spreader ring
4	Stem ball	24	Header ring
5	Ball spring	25	Stop plate
6	Gland	72	Weather seal
7	Gland screws	89	Lever or T-bar/adaptor
9	Cover	90	Lever screw
10	Cover screws	91	Lever washer
13	Sleeve	92	Fire seal
15	Stop pins	93	Cover gasket
16	Stop pin screws	94	Gland spring

NOTES

Model shown is stem size 1, other stem sizes have 2 chevron rings.

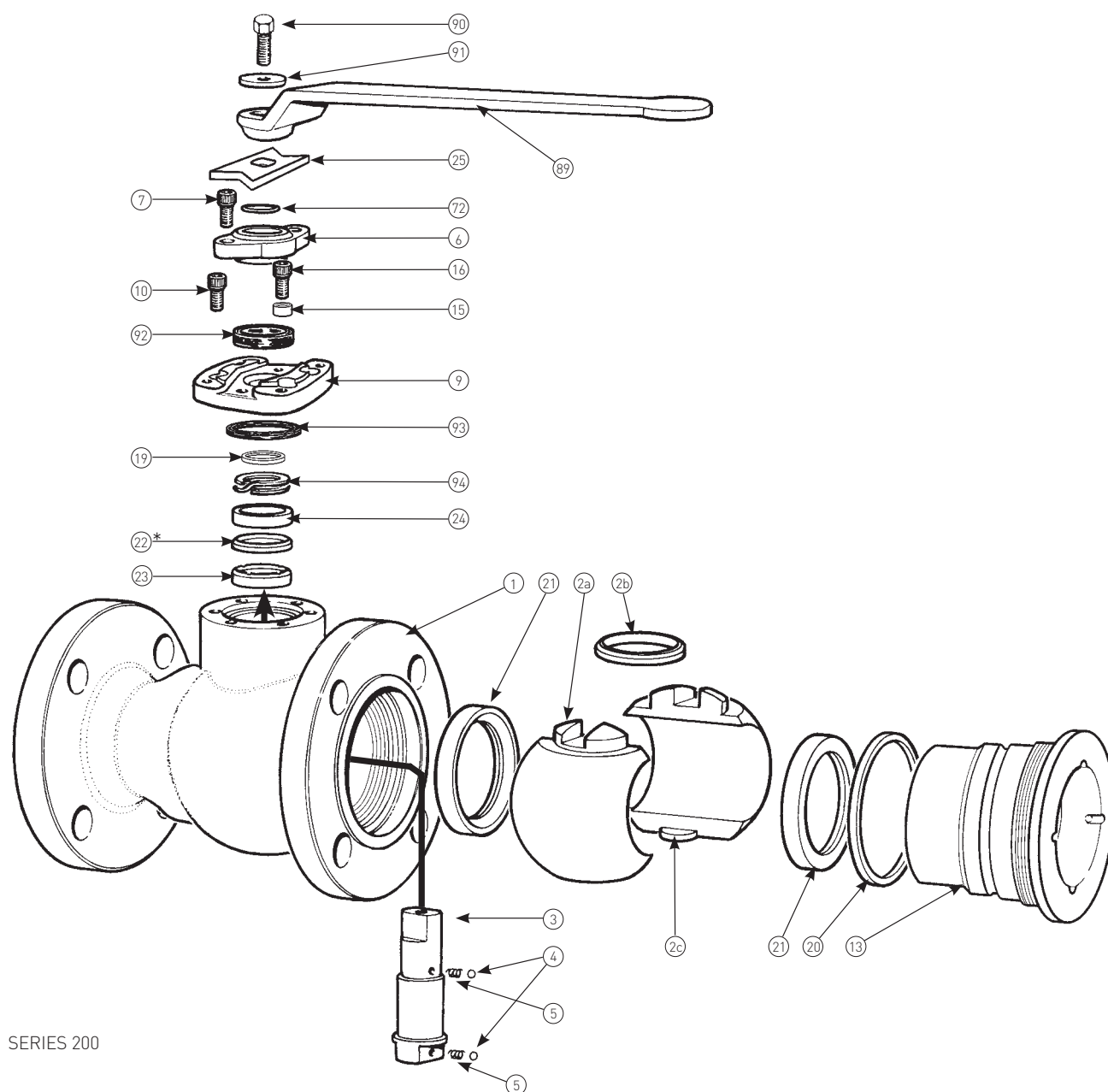

SERIES 200

KTM HINDLE ULTRA-SEAL BALL VALVES

OPERATION, INSTALLATION AND MAINTENANCE INSTRUCTIONS

Split ball - disassembly

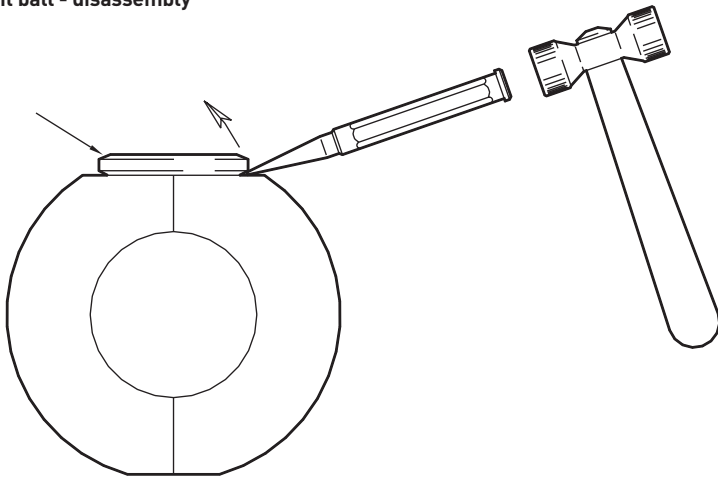

FIGURE 1
Removal of locking ring

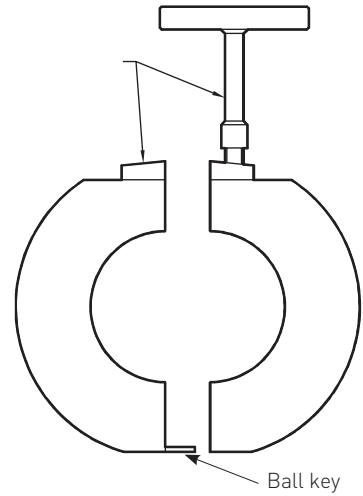

FIGURE 2
'T'-bar fits into tapped holes on top of ball halves, to lift from body

Gearbox - showing travel stop setting screws

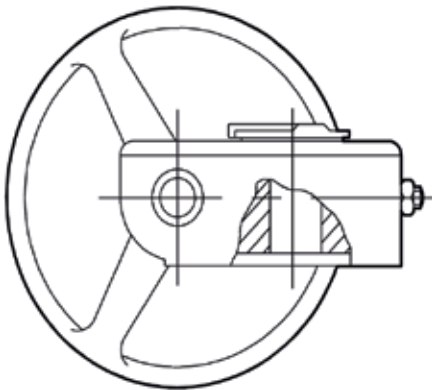

FIGURE 3
① Indicates closed position stop
② Indicates open position stop

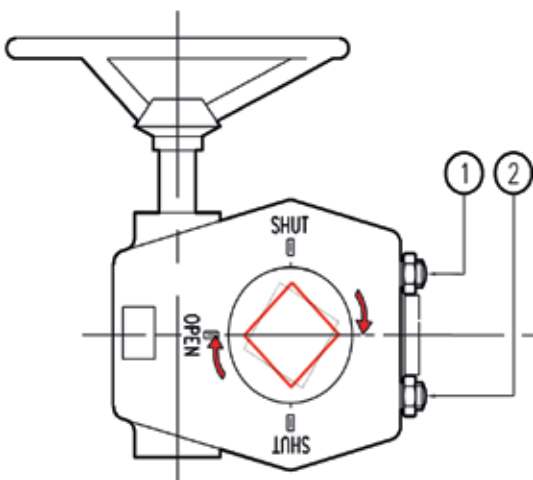
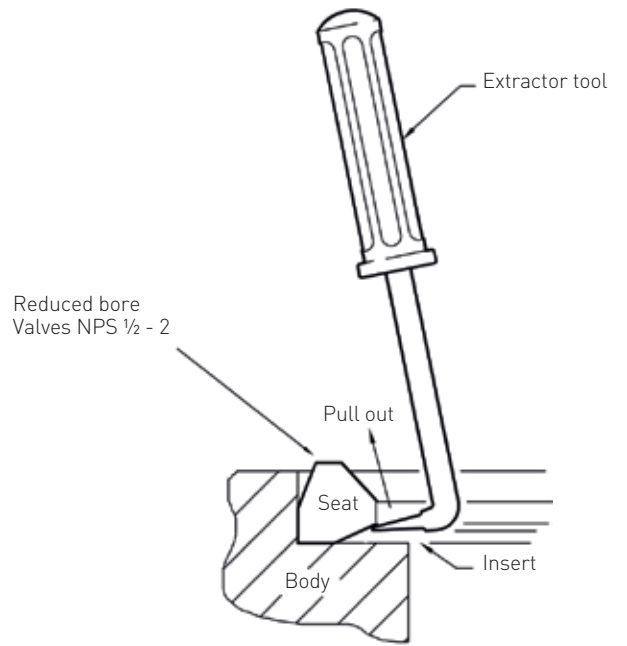
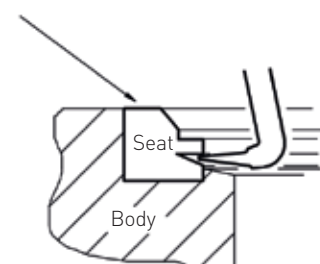

FIGURE 4
Align diamond drive with valve-bore center line - as indicated

Seat removal



Reduced bore valves NPS 3 - 16
Full bore valves NPS 2 - 14



Neither Emerson, Emerson Automation Solutions, nor any of their affiliated entities assumes responsibility for the selection, use or maintenance of any product. Responsibility for proper selection, use, and maintenance of any product remains solely with the purchaser and end user.

KTM is a mark owned by one of the companies in the Emerson Automation Solutions business unit of Emerson Electric Co. Emerson Automation Solutions, Emerson and the Emerson logo are trademarks and service marks of Emerson Electric Co. All other marks are the property of their respective owners.

The contents of this publication are presented for informational purposes only, and while every effort has been made to ensure their accuracy, they are not to be construed as warranties or guarantees, express or implied, regarding the products or services described herein or their use or applicability. All sales are governed by our terms and conditions, which are available upon request. We reserve the right to modify or improve the designs or specifications of such products at any time without notice.

Emerson.com/FinalControl