



KTM SERIES EB598 FLOATING BALL VALVE

3-piece, full bore, floating ball valve, suitable for a wide range of arduous applications for the oil and gas, petrochemical and process industries, where fire-safe design is mandatory



GENERAL APPLICATION

Industrial systems including water, condensate, oil, gas and chemical processes. Valves are designed for extended use in oil and gas production, petrochemical and chemical applications, in hazardous areas handling flammable fuels, gases or media where fire-safe valves are mandatory. Body material and trim components are NACE compliant.

TECHNICAL DATA

Size range: DN 8 - 40 (NPS ¼ - 1½)
Pressure rating: ASME Class 800
Temperature rating: Up to 260°C
End connections: Threaded BSPT, NPT, Socket weld and Butt weld

FEATURES

- Full bore valves provide an unrestricted flow path for higher flow rates.
- 100% of valves are pressure tested.
- Certificate of Compliance to EN 10204 / ISO 10474 Type 3.1 (DIN 50 049) are supplied as standard.
- Winged body design allows the mounting of actuators without having to remove the body bolts and maintain seal integrity.
- Three piece body allows swing out center section for fast and easy maintenance.
- Integral padlocking as standard on manual valves.
- Blow-out proof stem.
- Vented ball equalizes body cavity pressure in open position and prevents seat damage.
- Vented seats equalizes pressure over upstream seat when used in high differential pressure applications and thereby reduces operating torque.
- Fully machined carbon PTFE seats are standard ensuring bubble-tight shut-off.
- A choice of seating material options are available.
- Carbon steel or stainless steel body and end connections available.
- Full range of accessories, limit or proximity switches etc.
- Firesafe tested and certified to API607 6th Edition.
- Compliant to ASTM B16.34 API 608
 - CL800 Thread/Socket Weld
 - CL600 Buttweld
- ISO 17292
 - CL600 All options

KTM SERIES EB598 FLOATING BALL VALVE

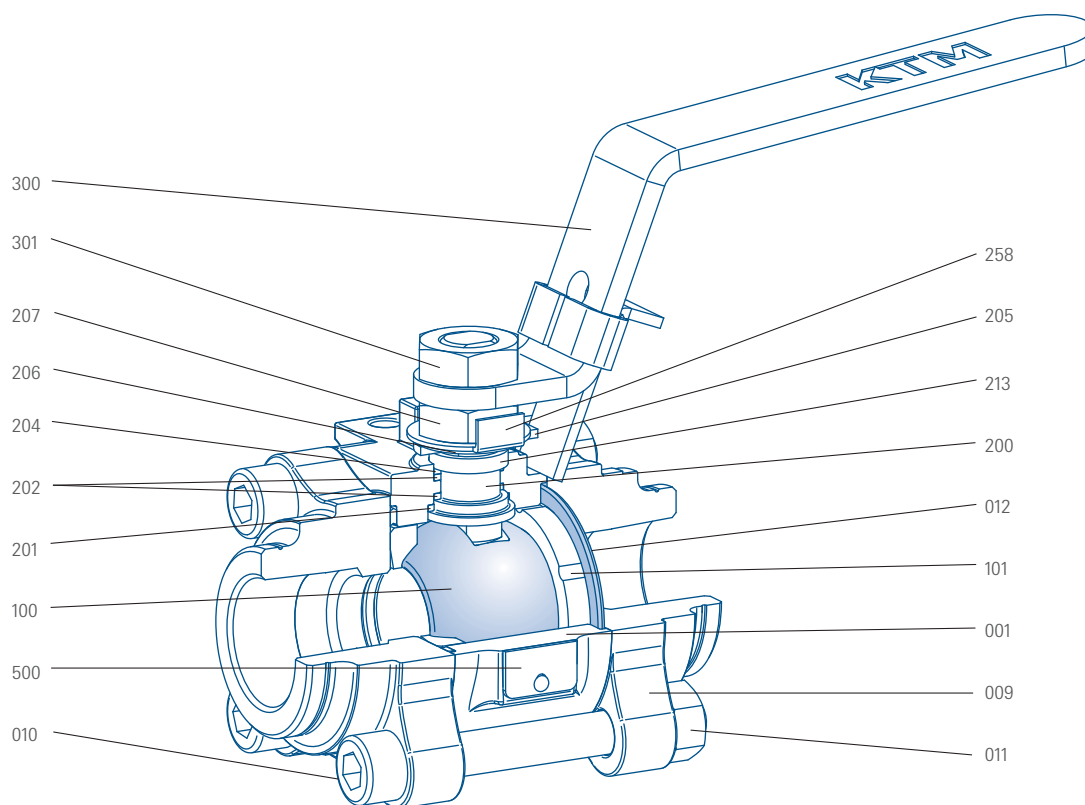

PARTS LIST

No.	Description	Carbon steel	Stainless steel
001	Body	ASTM A216-WCC	ASTM A351-CF8M
009	End connector	ASTM A216-WCC	ASTM A351-CF3M
010	Cap screw	316 S/S A4-80	316 S/S A4-80
011	Body nut	316 S/S A4-80	316 S/S A4-80
012	Body seal	316 S/S / Graphite	316 S/S / Graphite
100	Ball	UNS S31600	UNS S31600
101	Seat ring	Virgin PTFE, Carbon reinforced PTFE	Virgin PTFE, Carbon reinforced PTFE
200	Stem	UNS S31600	UNS S31600
201	Primary stem seal	Carbon reinforced PTFE	Carbon reinforced PTFE
202	Firesafe stem seal	Graphite	Graphite
204	Stem seal	Carbon reinforced PTFE	Carbon reinforced PTFE
205	Stop plate	UNS S30400	UNS S30400
206	Spring washer	Inconel	Inconel
207	Gland nut	UNS S31600	UNS S31600
213	Gland	UNS S31600	UNS S31600
258	Tab washer	UNS S31600	UNS S31600
300	Wrench	UNS S30400	UNS S30400
301	Wrench nut	UNS S31600	UNS S31600
500	Name plate	UNS S30400	UNS S30400

NOTE

* Carbon content 0.25% max.

KTM SERIES EB598 FLOATING BALL VALVE

END CONNECTIONS, STANDARDS AND ORDER CODES

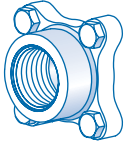

Screwed BSPT: Code B
Standard: BS 21 or ISO R.7

Screwed NPT: Code N
Standard: ASME B1.20.1

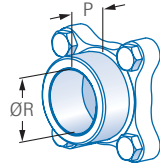

Socket weld pipe Sch.40:
Code S
Standard: ASME B16.11

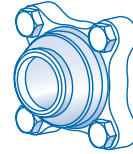

Butt weld pipe Sch.40:
Code W
Standard: ASME B36.10

PLAN VIEW OF VALVE STEM

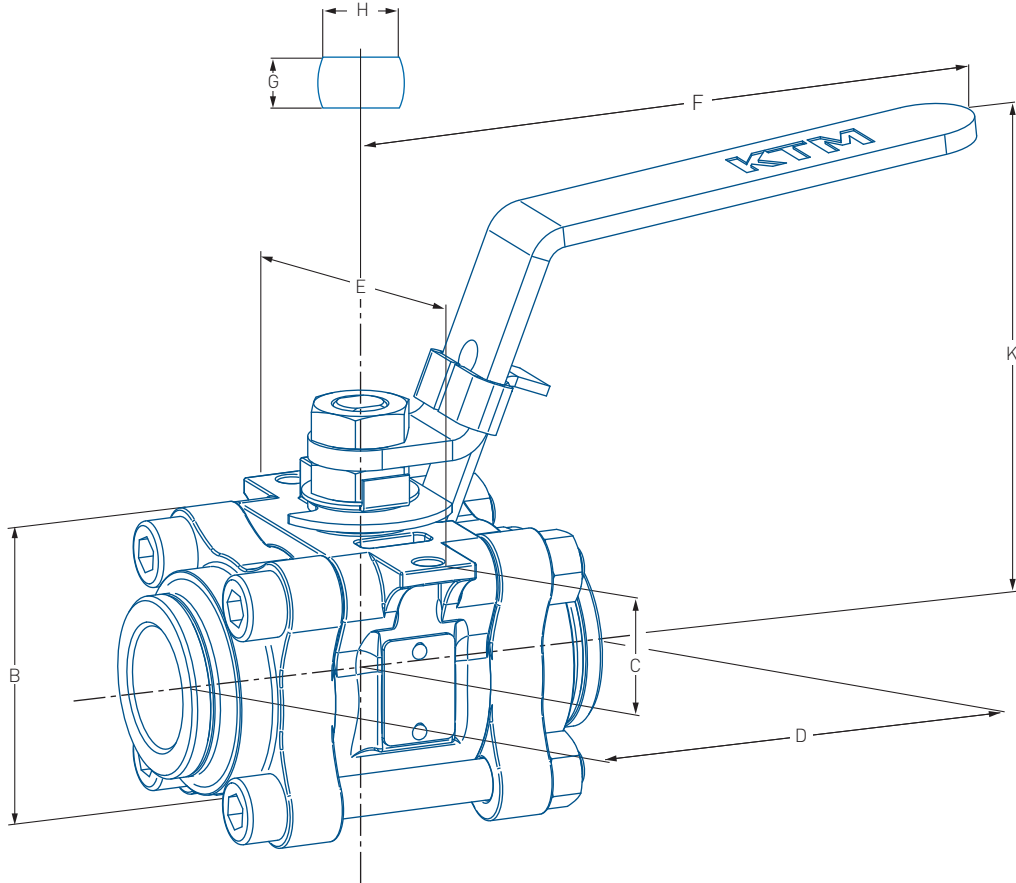

DIMENSIONS (mm)

Valve size DN	Port dia.	Stem conn. code	B	C	D	E	F	K	P	ØR	Stem conn. H x G (inches)	Top plate data			Mass (kg)	K _v at full open
												Center	No. holes	Hole dia.		
8	11.1	A	45.0	24.0	67	72	140	77	9.5	14.1	3/8 x 1/4	60.0	2	7	0.8	8.0
10	11.1	A	45.0	24.0	67	72	140	77	9.5	17.5	3/8 x 1/4	60.0	2	7	0.8	9.9
15	14.2	A	50.0	25.5	73	72	140	79	10.0	21.7	3/8 x 1/4	60.0	2	7	0.9	15.1
20	17.0	B	61.5	31.5	95	89	160	109	13.0	27.0	1/2 x 3/8	77.0	2	7	1.6	30.3
25	24.0	B	70.5	35.0	108	89	160	113	13.0	33.8	1/2 x 3/8	77.0	2	7	2.1	54.4
32	31.8	B	81.0	41.0	116	97	160	118	13.0	42.5	1/2 x 3/8	85.0 x 28.0	4	7	3.3	93.4
40	38.1	D	95.0	48.0	128	113	200	125	13.0	48.6	3/4 x 1/2	101.0 x 34.0	4	7	4.8	146.1

NOTE

B = The clearance dimension of the valve body and end connector.

H = The diameter of the stem connection.

G = The dimension across the stem flats.

K_v = The flow rate of water in m³/hr that will pass through a valve with a pressure drop of 1 bar (100 kPa) at 20°C.

C_v = 1.155 K_v.

Dimensions are nominal ±1mm.

KTM SERIES EB598 FLOATING BALL VALVE

PRESSURE/TEMPERATURE CHART

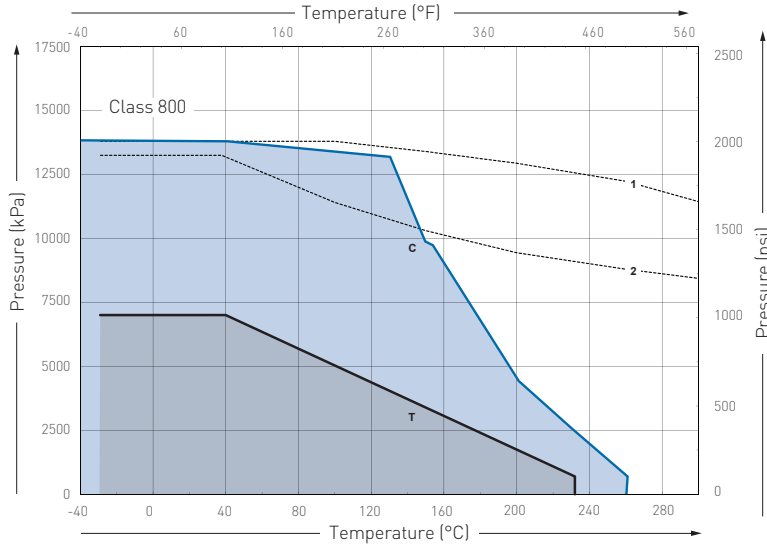

T - Virgin PTFE C - Carbon/Glass reinforced PTFE
 1 - WCC Body 2 - CF8M Body

PRESSURE/TEMPERATURE RATINGS

Virgin PTFE seated

DN 8 - 40 (NPS ¼ - 1½) 7 MPa/70 bar at 38°C

Carbon/glass reinforced PTFE seated

DN 8 - 40 (NPS ¼ - 1½) 13.8 MPa/138 bar at 38°C

NOTE

These pressure/temperature ratings are for the total valve assembly and with the respective seat material fitted. Carbon reinforced PTFE seats can be used in saturated steam/condensate service up to a maximum of 1.6 MPa/16 bar. Carbon steel valves have a minimum temperature limitation of minus 29°C.

TYPICAL SPECIFYING SEQUENCE

040	EB598	S	B	B	T	S	F	3	-	01
Valve size	Series no.	Body material	End conn. (note 1)	End conn. (note 1)	Seat type	Trim material	Body seal	Certification code (note 2)	Valve variant (note 3)	Standard option (note 4)

Size range: DN 8 - 40 (NPS ¼ - 1½)
 Series no.: EB598 - 3 Piece, Class 800, full bore, floating ball design ball valve
 End connections available: BSPT (B), NPT (N), Socket weld (S), Butt weld (W), Pipe pup weld ends (P)

FIRE SAFE - EXAMPLES

Trim code	Body material	End conn.	End conn.	Seat	Trim	Body seal
SBBTSF	316 S/S	BSPT	BSPT	Virgin PTFE	316 S/S	Graphite
SNNCSF	316 S/S	NPT	NPT	Carbon/Glass RTFE	316 S/S	Graphite
CBBTSF	Carbon steel	BSPT	BSPT	Virgin PTFE	316 S/S	Graphite
CNCSF	Carbon steel	NPT	SW	Carbon/Glass RTFE	316 S/S	Graphite

NOTE

- For end connection codes refer to Emerson. (1st code is under handle, 2nd code is non handle end).
- Certification according EN10204 3.1 (Material & Pressure Test) is supplied as standard (code 3).
- Valve variant: Standard valve is not offered with variants. Should a valve variant be required, refer to Emerson.
- Standard options: Base valve is supplied with wrench fitted locking device - Code 01. For other valve options, refer to Emerson for listing and order code details.
 For fitment of actuator, order requirement is to be specified as 'complete with' followed by the detail of the requirement - eg: complete with actuator.

Neither Emerson, Emerson Automation Solutions, nor any of their affiliated entities assumes responsibility for the selection, use or maintenance of any product. Responsibility for proper selection, use, and maintenance of any product remains solely with the purchaser and end user.

KTM is a mark owned by one of the companies in the Emerson Automation Solutions business unit of Emerson Electric Co. Emerson Automation Solutions, Emerson and the Emerson logo are trademarks and service marks of Emerson Electric Co. All other marks are the property of their respective owners.

The contents of this publication are presented for informational purposes only, and while every effort has been made to ensure their accuracy, they are not to be construed as warranties or guarantees, express or implied, regarding the products or services described herein or their use or applicability. All sales are governed by our terms and conditions, which are available upon request. We reserve the right to modify or improve the designs or specifications of such products at any time without notice.

Emerson.com/FinalControl