

June 2012

# Transfer Area Valving

## Introduction

Fisher™ offers a complete line of transfer area valving – Emergency Shut-off Valves (ESV), Back Check Valves, and Internal Valves – that complies with NFPA 58 requirements. All of these valves feature heavy-duty construction for long service life and can be used on LP-Gas as well as anhydrous ammonia (NH<sub>3</sub>). Only Fisher offers so many different valves for bulk plant and tank car applications, enabling you to find the right equipment for your particular needs.

## Snappy Joe™ Emergency Shut-off Valves

Two models of Snappy Joe ESVs are available: Type N550 for bulk plants and Type N562 for tank cars. The Type N550 is usually installed in-line behind a bulkhead. Operated manually under normal conditions, it can be remotely closed in an emergency by either a cable or loss of pneumatic pressure. The Type N562 is the only valve on the market specifically designed for tank car use. It is pneumatically opened and closed. Refer to Figures 1, 5, 6, 7, and 8 for Type N550 and Figures 2 and 12 for the Type N562.

## Back Check Valves

Where there is flow only into the stationary storage, an ESV does not have to be used to satisfy NFPA 58. On these applications, a heavy duty back check valve makes an excellent choice. G200 Series Back Check Valves can be supplied with or without built-in flow indication and offer very low flow resistance (refer to Figure 17).

## Internal Valves

Fisher Internal Valves have proven themselves to be reliable performers on bobtail, transport trucks, and bulk storage tanks. They can be opened and closed manually, pneumatically, or by cable. Complete information on the Type C477 is provided on page 9.



**Figure 1.** Type N550 Emergency Shut-off Valve



**Figure 2.** Type N562 Emergency Shut-off Valve



**Figure 3.** G200 Series Back Check Valve



**Figure 4.** Type C477 Jet Bleed Internal™ Valve

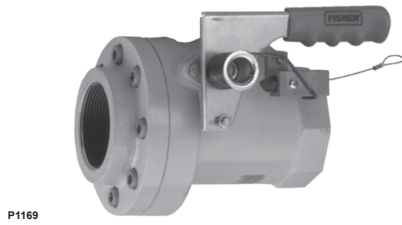

Figure 5. Type N550 (Valve Closed)



Figure 6. Type N550 with Type P539A

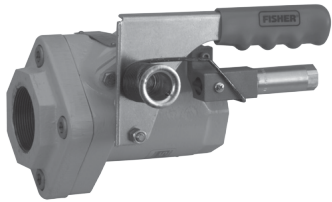

Figure 7. Type N550 with Type P327D

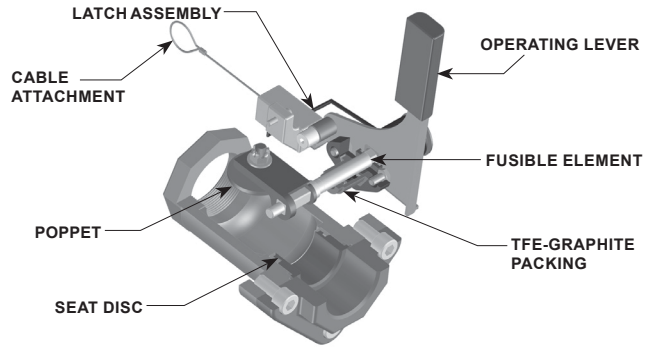

Figure 8. Type N550 In Open Position

Table 1. Type N550 Emergency Shut-off Valves

TYPE NUMBER	BODY SIZE	FLOW IN GPM / L/min PROPANE		ACCESSORIES
		1 psid / 69 mbar d	2 psid / 0.14 bar d	
N550-10	1-1/4 in.	50 / 189	75 / 284	Type P164B Cable Release Type P539A Pneumatic Actuator T1139599012 Control Valve
N550-16	2 in.	75 / 284	115 / 435	
N550-24	3 in.	190 / 719	275 / 1041	

## Type N550 Snappy Joe™ Emergency Shut-off Valves for Bulk Plants

Type N550 Emergency Shut-off Valves (ESVs) are designed for in-line installation, usually near a bulkhead. (Refer to Figures 9 and 10 for installation drawings). The valves provide an operator a means of shutting off the flow of product in the event of hose rupture, pull away, or piping break at the transfer area to avoid a large scale loss of LP-Gas or NH<sub>3</sub> from the storage tank.

Snappy Joes are manually opened, and can be closed manually at the installed location or remotely by either cable or air. A thermal release is built-in.

## Features

**Operational Ease**—Moving the operating lever to the vertical position opens the valve, making it simple to tell if the unit is open or closed. A pilot valve in the poppet opens as the lever is moved upward to pressurize the hose. This allows pressure to equalize, allowing the poppet to move quickly to the open position.

The valve is closed by simply pushing the lever down without first having to trip a latch. It is easy to reach the operating lever from across a bulkhead. All sizes look similar and operate exactly the same, an important point in an emergency situation.

**Cable Release**—Standard Snappy Joes are fitted with a release mechanism for cable attachment. Connecting a cable to the wire loop allows the valve to be closed from a safe remote location, such as the bulk entrance. While ordinary cable can be used, Type P164B cable release assemblies are available.

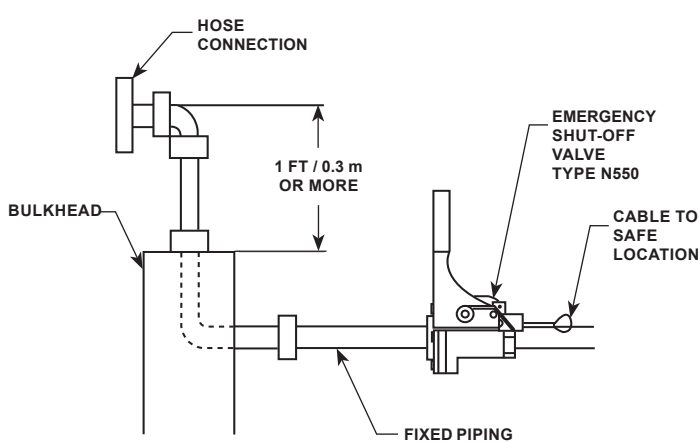

**Figure 9.** Installation Schematic of Type N550 with Type P164B cable

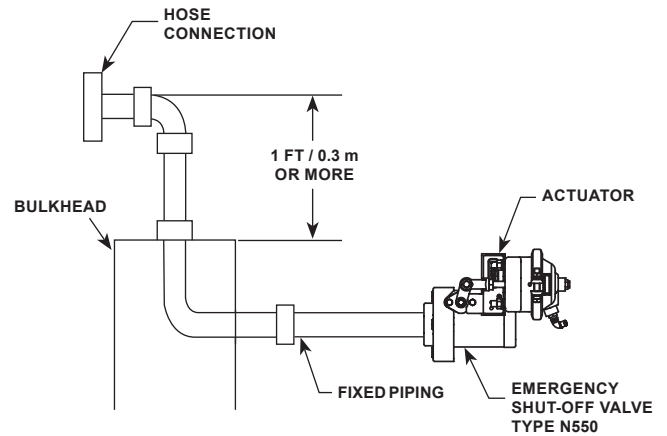

**Figure 10.** Installation Schematic of Type N550 with Type P539A Pneumatic Actuator

This assembly uses cable housing 50 ft / 15 m in length, which does not require elaborate guiding like uncovered cables.

**Rugged Construction**—Heavy-duty construction makes Snappy Joe™ ESVs suitable for use as a “working” shut-off valve for the transfer area, even under frequent use. The internal closing spring is protected from the elements and tampering. All seats and seals use metal back-up seals for extended fire resistance. PTFE-graphite packing forms an effective leak resistant seal around the stub shaft.

**High-Flow Capacity**—The main poppet moves out of the flow stream to permit extremely low restriction-to-flow. For example, the 2 in. body size flows 75 GPM / 284 L/min propane at 1 psig / 69 mbar pressure drop.

**Fusible Element**—The fusible element is located at the hub of the operating lever and stub shaft. If exposed to fire, the element melts allowing the stub shaft to turn. The poppet then moves to the closed position, even if the operating lever has been wired open.

**Soft Seat**—The synthetic rubber seat disc provides bubble tight shutoff. Since the seat disc is part of the seat ring, cutting or indentation of the seat is minimized, improving service life.

**Ease of Service**—The Type N550 is designed to be serviced without removal from the pipeline. Expected wearing parts are all external and can be changed out in a matter of minutes. The packing can be changed with the valve in-line.

**Pneumatic Operation**—The latch assembly can be quickly removed and a **Type P539A** pneumatic release substituted to control the valve by air or nitrogen. Pressure on the Type P539A allows the valve to be latched in the open position. Manual closure at the valve location requires an additional switching valve or dump valve. Loss of pressure permits the ESV to close.

Opening and closing of Snappy Joes ESVs from a remote location can be done by using **Type P539A** air actuator. The actuator opens the valve when around 20 to 30 psig / 1.4 to 2.1 bar air or nitrogen pressure is applied. Upon loss of pressure, the valve closes, assisted by the spring in the pneumatic actuator. All necessary installation hardware for the Type P539A is furnished.

A small three-way control valve for pneumatic ESV installation can be used as primary control (to open or close the ESV) or an auxiliary remote release (close only).

Placing the valve’s button in the upward position permits pressure to the actuator. Pushing the button down exhausts pressure to close all valves connected to the system.

### Type N550 Specifications:

Body Sizes – 1-1/4, 2, and 3 in. FNPT  
 Pressure Rating – 400 psig / 27.6 bar WOG  
 Body – Ductile Iron  
 Seat Disc – Synthetic Rubber with Metal Back-up  
 Packing – PTFE with Graphite/SST Back-up Ring

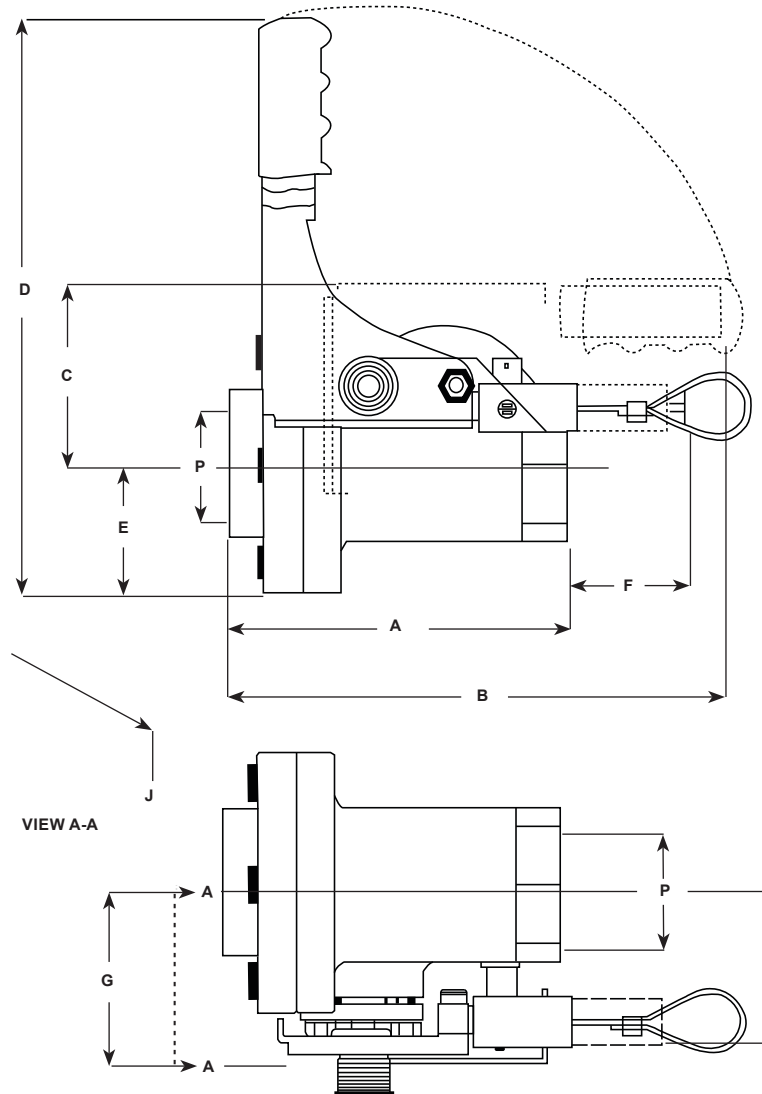

Figure 11. Type N550 Dimensions

Table 2. Type N550 Dimensions

P	IN. / mm								
	A	B	C	D	E	F	G	H	J
1-1/4 in.	5.9 / 150	9.6 / 244	3.4 / 86	10.4 / 264	2.0 / 51	3.6 / 91	5.1 / 130	3.2 / 81	5.5 / 140
2 in.	7.2 / 183	10.0 / 254	3.9 / 99	11.6 / 295	2.9 / 74	2.6 / 66	5.4 / 137	3.5 / 89	6.0 / 152
3 in.	9.2 / 234	10.6 / 269	4.5 / 114	12.9 / 328	3.5 / 89	1.2 / 30	5.7 / 145	4.2 / 107	6.5 / 165

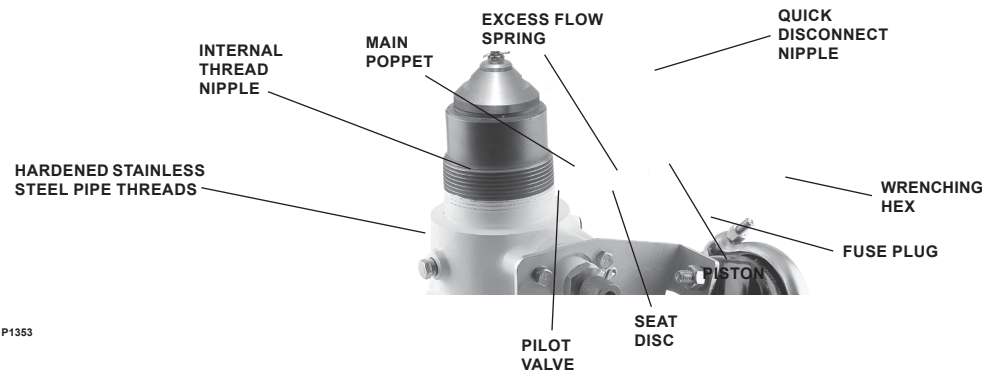

Figure 12. Type N562 Emergency Shut-off Valve

## Type N562 Snappy Joe™ Emergency Shut-off Valves for Railroad Tank Cars

**Type N562 Snappy Joe Emergency Shut-off Valves (ESVs)** are designed expressly for attachment to the shut-off valves on railroad tank cars. (Refer to Figure 13 for installation drawing.) Typically three Type N562s will be used – two on the liquid lines and one on the vapor line. NFPA 58 regulations call for ESV protection on both sides of the transfer hose or piping.

While conventional Type N550 ESV, which are intended for bulkhead installations can be used on tank car service, they are generally unsatisfactory for this application because they are too bulky for easy handling on top of a tank car.

The Type N562 is pneumatically opened and closed at the valve by means of a standard quick-disconnect coupling (furnished with the valve). Depending upon the pressure in the tank car, approximately 20 to 60 psig / 1.4 to 4.1 bar is needed to open the valve.

Remote closure from one or more points, such as the unloading riser, is accomplished by exhausting pressure from the valve's piston chamber with a pneumatic control valve.

### Features

**Light Weight**—Type N562 ESVs weigh approximately 14 pounds / 6 kg, making them easy to handle at the unloading riser. In addition, the valve is shaped like an elongated pipe fitting to facilitate connection to the tank car shut-off valves.

**Application Flexibility/Filed Serviceability**—The Type N562 has a female coupling. Nipple lengths are field selectable based on specific application requirements such as the size of the tank dome opening. These field-installed nipples can be easily secured and replaced.

Table 3. Type N562 Emergency Shut-off Valves

TYPE NUMBER	SHUT-OFF VALVE CONNECTION	HOSE CONNECTION
N562-16	2 in. FNPT	2 in. Male Acme
N562-18		2-1/4 in. Male Acme
N562-26		3-1/4 in. Male Acme

**Hardened Threads**—The 2 in. FNPT hardened stainless steel threads on the nipple portion of the Type N562 hold up against repeated replacement of field-installed nipples.

**Wrenching Hex**—To further ease attachment, a wrenching hex is built into the body and nipple, preventing wear or damage when connecting or disconnecting. A 1/4 in. FNPT opening in the hex portion can be used to install a bleed valve.

**No External Moving Parts**—All moving parts are inside the Type N562 to help minimize damage from rough handling. Should the quick-disconnect nipple be damaged, replacements are widely available through air supply outlets.

**Excess Flow Valve**—With a poppet design similar to Fisher's internal valve series, it is possible to incorporate an excess flow spring. The spring has a closing flow of 200 GPM / 757 L/min propane at 13 psid / 0.90 bar d.

**Fuse Plug**—Thermal protection is furnished by a steel cased fuse plug which melts if exposed to 212°F / 100°C. When the plug melts, pressure can escape from the piston chamber, closing the valve.

**Dual Service**—Since the body and all internal parts are either stainless steel or plated steel, the Type N562 can be used on LP-Gas and NH<sub>3</sub> service.

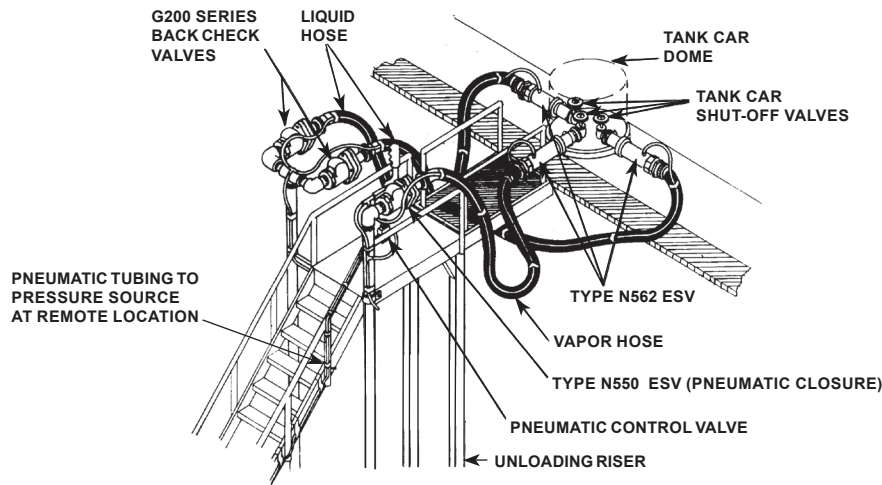

Figure 13. Installation Schematic of Type N562 and Related Equipment on Unloading Riser

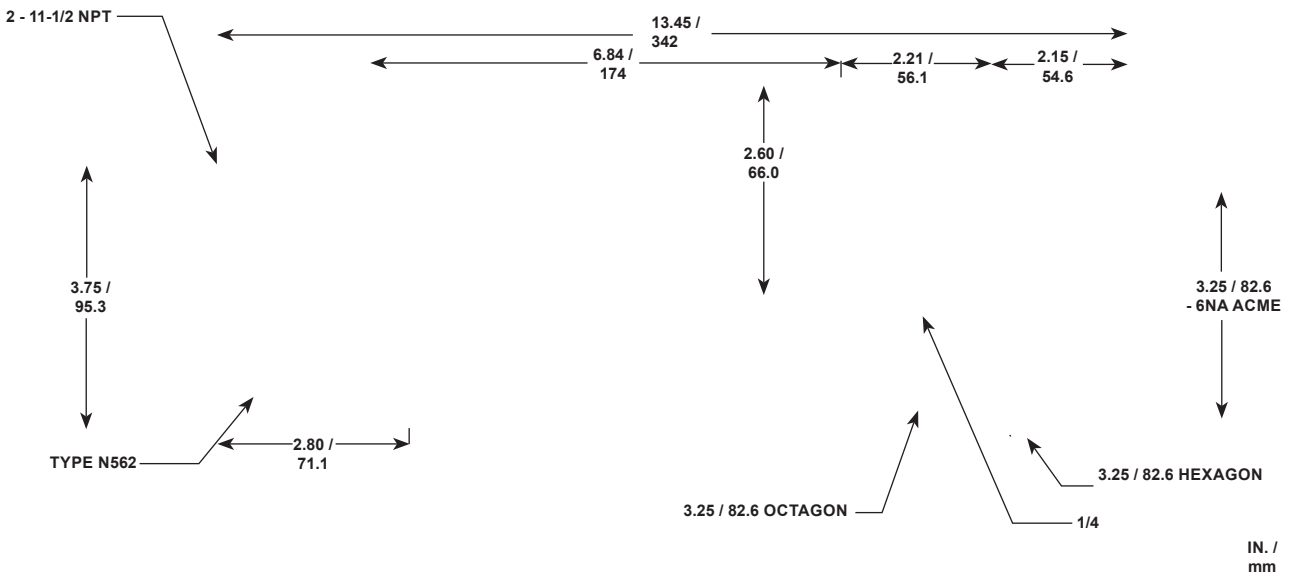

Figure 14. Type N562 Dimensions

### Pneumatic Closure Accessories

Pneumatic controls and fittings are needed to remotely close the Types N562 and N550/P539. (Refer to pages 2 to 5). Fisher™ does not manufacture these items, but these accessories are readily available from a number of sources. A listing of pneumatic accessories that appear to be suitable follows. Fisher has not extensively tested any of this equipment and cannot guarantee these components will function satisfactorily under all conditions.

### Control Valves

The push-to-close button type (using the palm of your hand) of pneumatic control valve appears to be the best choice as a remote closure valve. It is usually easy to see if the valve is open or closed, and it's also easy to close the valve quickly in an emergency situation.



P1041

Figure 15. Type G201 with Flow Indicator

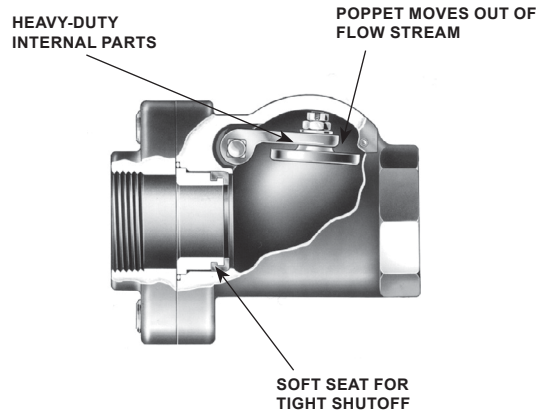

Figure 16. Type G200/G201 Sectional View

Table 4. Types G200 and G201 Back Check Valves

TYPE NUMBER		SEAT CONSTRUCTION	CONTAINER OR INLET CONNECTION	OUTLET CONNECTION	PROPANE FLOW CAPACITY AT 10 psig / 0.69 bar DIFFERENTIAL PRESSURE
Ductile Iron					
Standard	Flow Indicator				
G200-10	G201-10	Soft Seat	1-1/4 FNPT	1-1/4 FNPT	190 GPM / 719 L/min
G200-16	G201-16		2 FNPT	2 FNPT	350 GPM / 1325 L/min
G200-24	G201-24		3 FNPT	3 FNPT	800 GPM / 3028 L/min

## Types G200 and G201 Back Check Valves

**G200 Series** Back Check Valves are specifically intended for heavy-duty, in-line service at the bulk plant's transfer area. (Refer to Figure 17 for installation drawing.) As with conventional back check valves, the G200 Series permits flow in one direction only. Flow moves the spring-loaded poppet to the open position as soon as a pressure differential is created. When flow stops, the poppet closes. The valves are suitable for LP-Gas or NH<sub>3</sub> service.

### Features

**Rugged Construction**—Type G200s are built to stay on the job with all internal parts of plated steel or stainless steel.

**High-Flow Capacity**—With body construction similar to the Snappy Joe™ Emergency Shut-off Valves, resistance to flow is very low. For example, the 2 in. body size flows 350 GPM / 1325 L/min propane at 10 psig / 0.69 bar differential pressure.

**Soft Seat**—This construction gives tight shutoff so that piping can be blown down for maintenance.

**Flow Indicator**—The Type G201 has a built-in flow indicator mechanism, which can be used to replace sight flow indicators.

### Type G200/G201 Specifications:

- Body Size – 1-1/4, 2, and 3 in.
- Pressure Rating – 400 psig / 27.6 bar WOG
- Body – Ductile Iron
- Internal Parts – Plated Steel or Stainless Steel
- Seat Disc – Synthetic Rubber

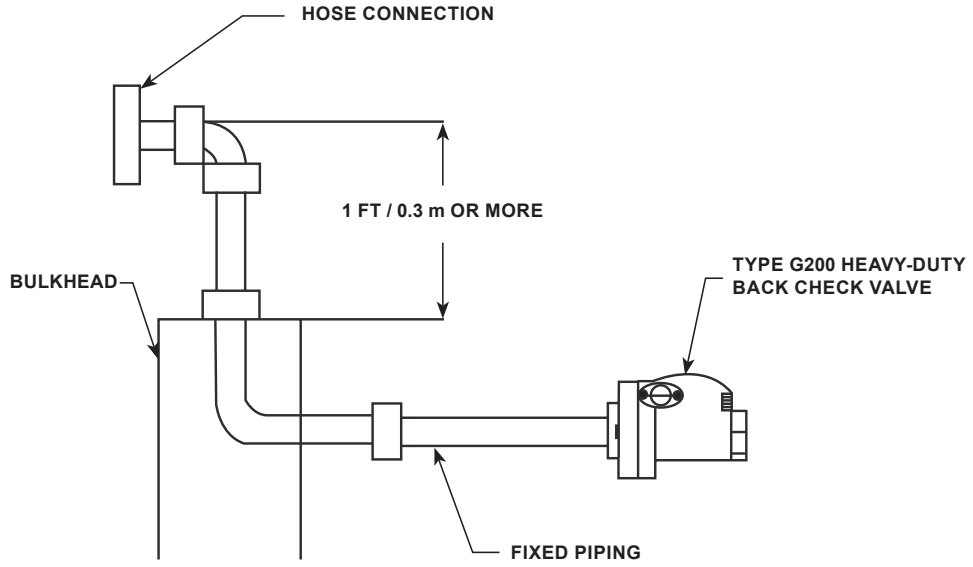

Figure 17. Type G200 Installation Schematic

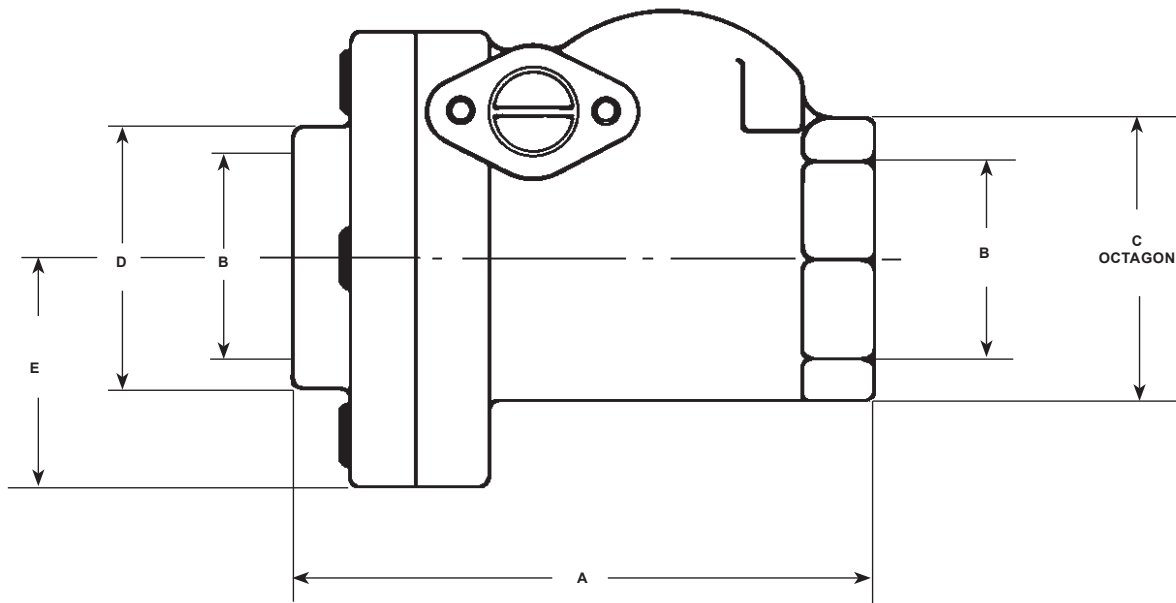
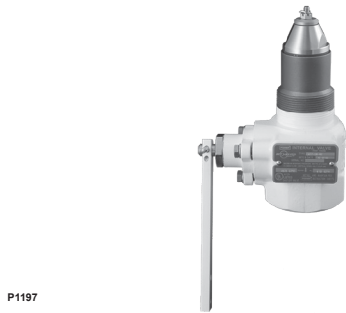

Figure 18. Types G200 and G201 Dimensions

Table 5. Types G200 and G201 Dimensions

BODY SIZE	IN. / mm				
	A	B	C	D	E
1-1/4 in.	5.9 / 150	1-1/4	2.4 / 61	2.3 / 58	2.0 / 51
2 in.	7.2 / 183	2	3.3 / 84	3.3 / 84	2.9 / 74
3 in.	9.2 / 234	3	4.5 / 114	4.5 / 114	3.5 / 89



P1197

**Figure 19.** Type C477 Jet Bleed Internal Valve

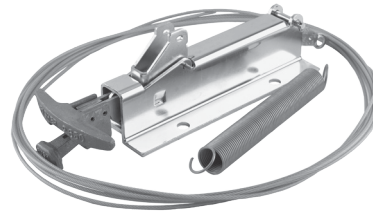

P1118

**Figure 20.** Type P650 Primary Cable Control



P1108

**Figure 21.** Type P340 Manual Latch



P1350

**Figure 22.** Type C477 with Type P639 Actuator

## Type C477 Jet Bleed Internal™ Valves

**Type C477** Jet Bleed Internal Valves are used on tank installations. The valve can be operated in a number of ways: (1) with a Type P650 or P651 primary cable control, (2) with a Type P340 latch/remote release mechanism, or (3) with a P600 Series actuator. Type C477 valves can function as Emergency Shut-off Valves with any of these operators or can supplement the ESVs for added safety and control.

## Features

**Versatile**—Internal valves give primary shutoff and also act as a back check valve or an excess flow valve. All critical shutoff parts are located within the tank, and a spring return can be installed on the valve's operating lever.

**PTFE Packing**—Spring loaded PTFE packing protects against product leakage around the stub shaft. The entire bonnet-stub shaft-cam assembly can be easily removed from the body by taking out three bolts.

**Primary Cable Control**—**Type P650 or P651** primary cable controls open and close a valve from a remote point, usually the rear of the bobtail or transport. Pulling the handle of the primary control opens the internal valve; pushing the handle closes the valve.

Included with each Type P650 primary control is a 20 ft / 6.10 m cable. Type P134 fusible links, a return spring and mounting hardware. If just the primary cable control is needed, order Type P651, which is available without any of the other accessories.

**Latch/Release**—**Type P340** release assemblies mount to the 2 and 3 in. threaded NPT sized Type C477 to give remote valve closure and fuse link protection. A **Type P163A** cable release can provide thermal actuation of the Type P340 from the bulkhead. (Refer to Figure 23 for installation drawing.)

**Pneumatic Actuation**—**Type P639** pneumatic actuators are available for Type C477, which permit remote opening and closing of several valves in a complex installation.

**Special Trim**—Standard disc material is Nitrile, but PTFE, FFKM, and FKM are also available. Steel and stainless construction are available.

## Type C477 Specifications:

Valve Sizes – 2 and 3 in. / DN 50 and 80  
 Pressure Rating – 400 psig / 27.6 bar WOG  
 Body – Ductile iron  
 Packing – PTFE  
 Seat Discs – Synthetic Rubber  
 Stub Shaft and Stem – Stainless Steel

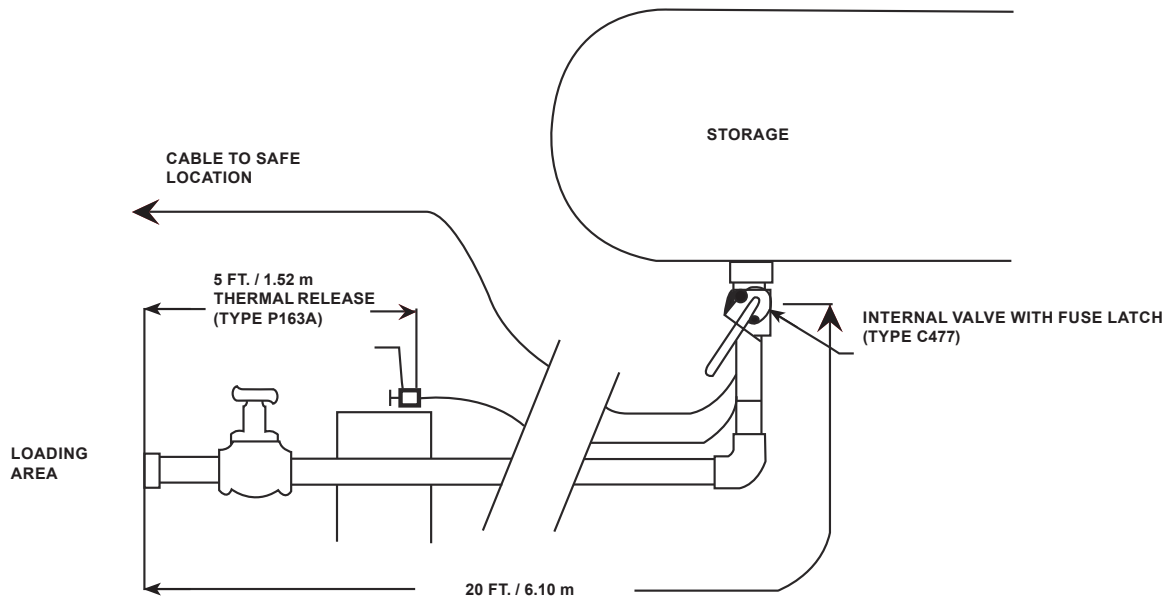
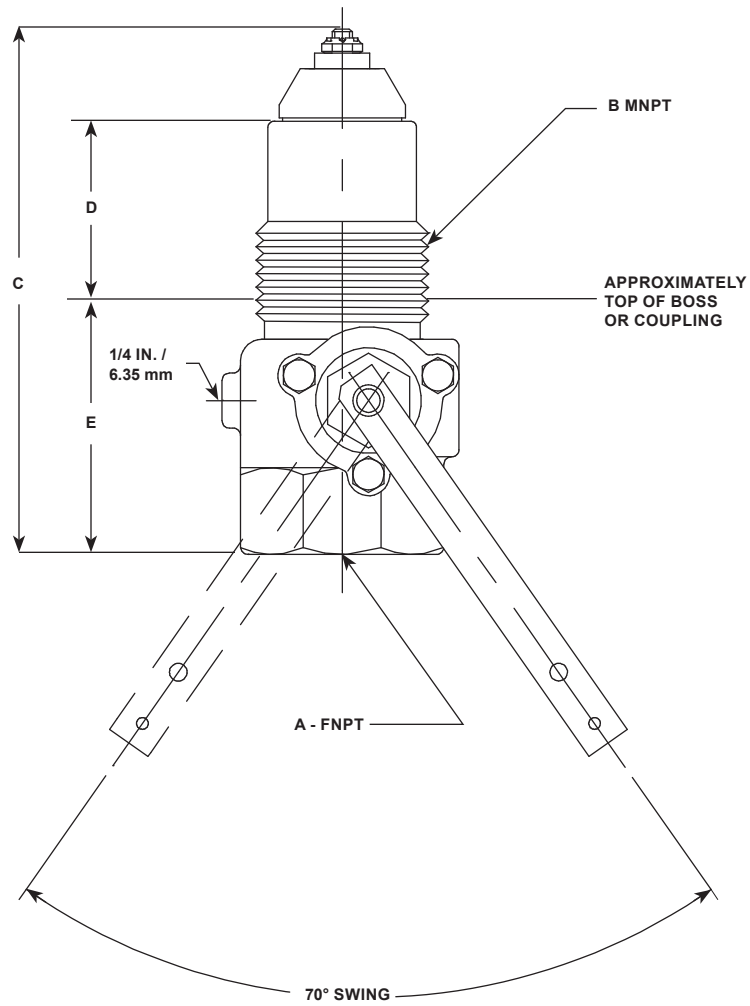

**Figure 23.** E.S.V. Installation Schematic of Types C477 and P163A

**Table 6.** Type C477 Jet Bleed Internal™ Valves

CONNECTIONS INLET X OUTLET	TYPE NUMBER		CLOSING FLOW GPM / L/min PROPANE <sup>(1)</sup>		VAPOR CAPACITY SCFH / SCMH PROPANE <sup>(1)</sup>	
	Straight Body	Tee Body	Half Coupling	Full Coupling	25 psig / 1.7 bar Inlet	100 psig / 6.9 bar Inlet
2 MNPT x 2 FNPT	C477-16-10	C471-16-10	100 / 379	60 / 227	26,100 / 739	45,000 / 1274
	C477-16-15	C471-16-15	150 / 568	90 / 341	39,400 / 1116	69,000 / 1954
	C477-16-25	C471-16-25	250 / 946	130 / 492	----	----
3 MNPT x 3 FNPT	C477-24-16	C471-24-16	160 / 606	120 / 454	41,100 / 1164	71,000 / 2011
	C477-24-26	C471-24-26	265 / 1003	230 / 871	71,800 / 2033	127,000 / 3596
	C477-24-37	C471-24-37	375 / 1419	320 / 1211	99,000 / 2803	178,000 / 5040
	C477-24-46	C471-24-46	460 / 1741	380 / 1438	----	----

1. Closing Flows and Vapor Capacities listed are with valve in "bottom of tank" position. See product bulletins for additional data.



IN. / mm

Figure 24. Type C477 Dimensions

Table 7. Type C477 Dimensions

TYPE NUMBER	A FNPT	B MNPT	C	D	E	INSTALLATION CLEARANCE DIAMETER
						In. / mm
C477-16	2	2	8.07 / 205	2.40 / 61	4.05 / 103	10.00 / 254
C477-24	3	3	9.00 / 229	2.60 / 66	4.57 / 116	13.38 / 340

✉ [Webadmin.Regulators@emerson.com](mailto:Webadmin.Regulators@emerson.com)

🔍 [Fisher.com](http://Fisher.com)

📘 [Facebook.com/EmersonAutomationSolutions](https://Facebook.com/EmersonAutomationSolutions)

🌐 [LinkedIn.com/company/emerson-automation-solutions](https://LinkedIn.com/company/emerson-automation-solutions)

🐦 [Twitter.com/emr\\_automation](https://Twitter.com/emr_automation)

## Emerson Automation Solutions

### Americas

McKinney, Texas 75070 USA  
T +1 800 558 5853  
+1 972 548 3574

### Europe

Bologna 40013, Italy  
T +39 051 419 0611

### Asia Pacific

Singapore 128461, Singapore  
T +65 6777 8211

### Middle East and Africa

Dubai, United Arab Emirates  
T +971 4 811 8100

D450157T012 © 2001, 2012 Emerson Process Management Regulator Technologies, Inc. All rights reserved. 07/20.

The Emerson logo is a trademark and service mark of Emerson Electric Co. All other marks are the property of their prospective owners. Fisher™ is a mark owned by Fisher Controls International LLC, a business of Emerson Automation Solutions.

The contents of this publication are presented for informational purposes only, and while every effort has been made to ensure their accuracy, they are not to be construed as warranties or guarantees, express or implied, regarding the products or services described herein or their use or applicability. All sales are governed by our terms and conditions, which are available upon request. We reserve the right to modify or improve the designs or specifications of such products at any time without notice.

Emerson Process Management Regulator Technologies, Inc does not assume responsibility for the selection, use or maintenance of any product. Responsibility for proper selection, use and maintenance of any Emerson Process Management Regulator Technologies, Inc. product remains solely with the purchaser.

