

March 2010

Safety Practices for Domestic Tank Fittings

Domestic tank fittings, like any other type of mechanical equipment, require periodic maintenance and inspection because operating problems can occur. Tank fittings are of vital importance in the LP-Gas system from a safety standpoint since they contain and control the product. Everyone handling LP-Gas should be aware that there is a limit to the number of years a tank fitting can remain in service without malfunctioning due to damage and wear. Since this time limit can vary widely due to service conditions, a periodic inspection routine is especially valuable. The following examines ways to avoid and correct potential safety hazards with the most common domestic tank fittings.

Filler Valves

These valves historically have been subject to more operating difficulties than any other fitting. This is probably because the filler valve must open and close more than other fittings and is subjected to high flow surges, product impurities and rough handling. Problems occur, of course, when the valve fails to close. The filler valve could stick in the wide open position or permit only a small leak past its rubber seat disc. In either case, a hazardous condition results from the escaping gas and corrective action must be taken.

The serviceman could encounter the valve sticking wide open if he quickly disconnects the hose end connection and finds gas rapidly escaping from the tank. Here would be an extreme hazard because there is no way to stop the escape of gas. Hazards of this type can be avoided by not completely disconnecting the Acme coupling until all pressure is bled off. If the pressure does not dissipate, the filler valve has malfunctioned. Never disconnect the hose end under this circumstance.

If light tapping on the valves does not close it, the tank could have to be emptied before the hose can be disconnected. However, if a filling hose adaptor back check (such as Fisher™ M460 or Rego 7577V) is used between the filler valve and the hose end valve, the adaptor can be left on a filler valve which fails to close. Then the hose end valve can be removed from the adaptor.

At other times, a filler valve may not completely shut off even though pressure does bleed off before the hose end adaptor is disconnected. A small leak past the seat disc can sometimes be discovered only by applying a leak-detector solution over the seat seal and watching for bubbles. Small leaks waste gas and may also create hazards. Of course, all filler valves should be tightly capped when not in use.

Never jab a tool or some other object at the valve's poppet in an attempt to make the filler valve seat. Such attempts can damage the poppet so badly that even changing the seat disc will not stop the leakage, making replacement of the filler valve necessary. Tapping the side of the valve may help it to seat, but don't tap hard enough to further damage the valve. Also never tap on the Acme threads and never use a tool that could make a spark.

Underwriters' Laboratories require that the seat disc in filler valves be replaceable under pressure. It should be kept in mind that the internal construction of filler valves differs from manufacturer to manufacturer, and *use only the correct spare parts for the particular valve*. The drawings in Figure 1 show how the disc can be replaced in valves of differing construction, i.e., two-piece and one-piece body designs. Since some gas will be lost because of the metal-to-metal lower back check, caution is necessary during disc replacement.

Filler valves of the two-piece body construction should be tested to make sure the lower back check is still functional before attempting to take the valve apart. The test can be made by forcing the upper back check open with a Fisher M450A or Rego's 3120 or 3119 adaptors. *Take care to dislodge only the upper back check and not both of the back checks. If there is just a little leakage with the upper back check open, then the lower back check is in place and the disc replacement procedure can commence.*

CAUTION

If the lower check is missing and the filler valve's upper body is unscrewed, there is nothing to contain the LP-Gas within the tank and a very hazardous condition results. A few of the older tanks may not have a separate liquid withdrawal valve, indicating that the filler valve also serves for liquid withdrawal purposes. This can be determined by using an adaptor as described above to slightly open the valve's upper back check. If significant leakage occurs, the disc should not be replaced under pressure because the leakage represents too great a hazard.

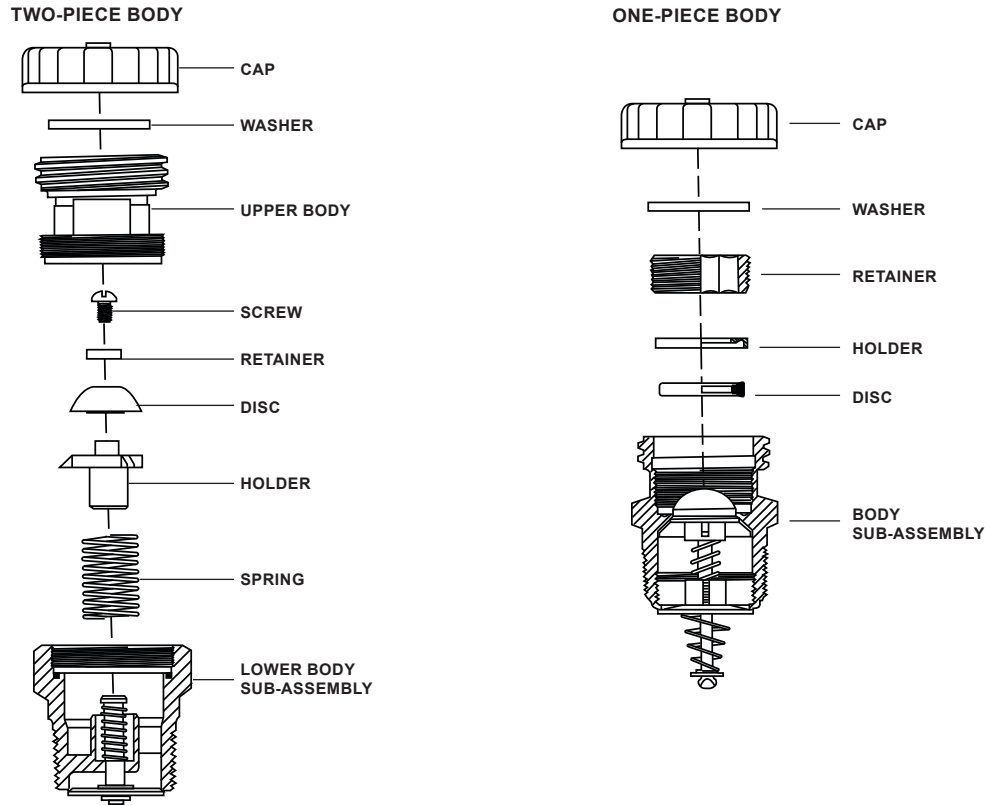

Figure 1. Exploded View of Typical Filler Valve Constructions

Relief Valves

The relief valve's purpose is to relieve excessive tank pressure by venting gas until the pressure drops. Excess pressure can be caused by overfilling, improper purging of air, or possibly from overheating of the product. If the relief valve is found to be discharging slightly, check the pressure gauge on the tank. When pressure is in the 240 to 260 psig / 16.5 to 17.9 bar range, the valve is functioning properly by discharging gas. At no time should a person approach or stand directly over a relief valve when tank pressure is high. The valve could pop wide open at any moment, blowing gas, dirt and other debris into a person's face and eyes.

These procedures are suggested for checking relief valves that leak:

1. Check to see if the valve reseats as tank pressure drops. If it does, the unit is doing exactly what it's intended to do, provided tank pressure was in the 240 to 260 psig / 16.5 to 17.9 bar range. Tank pressure could be lowered by either removing product from the tank or cooling the outside of the tank with water.
2. Do not attempt to force the valve closed! This could cause a tank rupture and will probably damage the relief valve.
3. If you find a relief valve that starts discharging when tank pressure is substantially below 240 psig / 16.5 bar, it means the valve is malfunctioning and will have to be replaced after the tank is emptied.

Water, dirt and other foreign materials are the enemies of the relief valve because they can damage its poppet and seat. A small drain hole in the lower portion of the upper body has been provided, and this opening should always remain unobstructed. There also should be a raincap placed on the valve to protect it from water and debris. Some relief valves utilize internal guiding for the main stem and appear as viewed from above in Figure 2, drawing B. Other relief valve styles have wings on the poppet for external guiding, as in drawing A.

Relief valves with wing guides are especially susceptible to corrosion. The wing guides can become "welded" to the guide surface due to prolonged exposure, preventing the valve from opening as required. If these wing guides are found to be corroded or jammed by dirt, the entire valve needs to be replaced. Relief valves are precisely set by the manufacturer for the correct start-to-discharge setting, and field repair should never be attempted. Since the disc in a relief valve is subject to normal deterioration, Fisher™ recommends that a relief valve not be used for longer than 15 years (almost all valves carry the date of manufacture). Earlier replacement may be required due to severe service conditions.

Liquid Withdrawal Valves

Tradenamed SafEvac®, Chek-Lok® or Checkmate®, these units are for evacuating liquid from the tank. They are installed on the top, side or bottom of the container, depending on the internal construction of the tank, and are not intended for use as a normal liquid outlet. During the evacuation process,

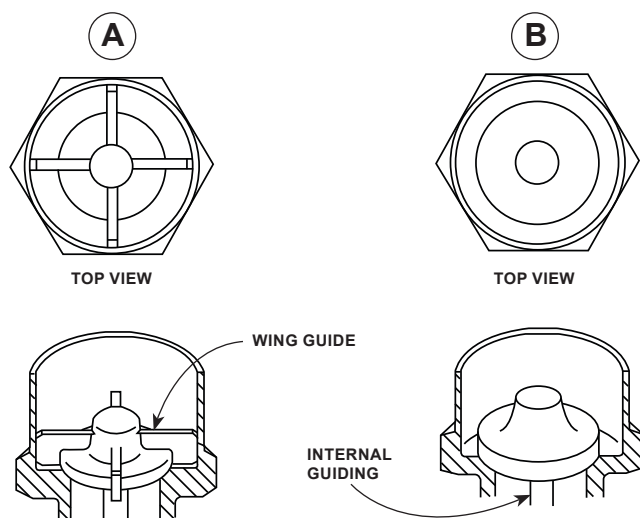

Figure 2. Relief Valve poppets with Internal Guiding or Wing Style Guides

the unit also acts as an excess flow valve. Most of the liquid withdrawal valves in the field today have metal-to-metal seats, and product loss will take place when making connection to the units.

In some cases, a damaged seat may allow an excessive amount of liquid to be discharged when the closing cap is loosened. A bleed hole in the closing cap has been provided to vent the liquid before the cap is completely unscrewed. If a significant amount of liquid continues to be blown from under the closing cap for more than 30 seconds, it can be assumed that the internal seat will not prevent a dangerous amount of gas from escaping. Do not remove the cap if in doubt. This is particularly true if the tank is located in a congested area, such as a mobile home park. Should only vapor be leaking from under the cap, the connection to the liquid withdrawal valve can usually be made.

Most newer designs of these valves contain a soft seat which helps to reduce substantially the amount of liquid or vapor vented when the closing cap is unscrewed. Such a valve is shown in Figure 3.

Once the closing cap is removed, it is valuable to have a full understanding of how the valve works. The valves contain a mechanism which is activated by screwing in an unloading adaptor or a pipe nipple. As the adaptor or pipe nipple opens the valve's bleed seat (increasing product leakage through the valve), the main valve poppet opens once the pressure equalizes, as shown in drawings A and B, Figure 3. As soon as the adaptor seals to the withdrawal valve, closing the angle valve, drawing B, permits the main poppet to open. The system is now ready for liquid withdrawal when the transfer equipment is connected.

The special unloading adaptors for these valves made by different manufacturers have slightly different gasket designs and may leak somewhat if mated to a different brand valve.

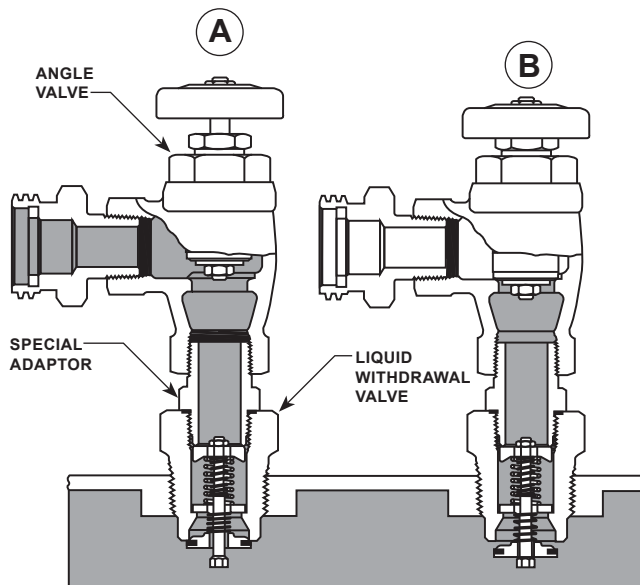

Figure 3. Operational Drawing of a Liquid Withdrawal

Instead of the special adaptors, an ordinary 3/4 in. MNPT pipe nipple could be used to open the valve. However, some brands of valves can be damaged if the nipple is screwed in too far so care must be taken if a pipe nipple is used, and the nipple may not seal completely.

A common operating practice is to first attach an unloading adaptor to an angle valve, see Figure 3, and then screw this assembly into the liquid withdrawal valve. The angle valve is kept open to prevent the main poppet from opening. As the angle valve-special adaptor assembly is being screwed into the withdrawal valve, the bleed through the withdrawal valve is coming out of the open angle valve (remember the withdrawal valve bleed is being forced open). There's a chance some liquid could spray out of the angle valve as it is rotated. Because of the possibility of liquid spray, proper protective clothing must be worn and extreme care taken throughout the entire process.

Disconnecting the unloading adaptor after tank evacuation also requires care to see that the valve's built-in excess flow shutoff parts were not jammed open by tank debris. The excess flow must be "slugged" shut by sudden discharge and not be allowed to open again while the adaptor is unscrewed. The manufacturer's instruction sheet covers this aspect in more detail.

Service Valves

Valves of this type, called ComboValve[®], MultiValve[®] or Unipac[®], offer fewer potential problems than other fittings, but they still should not be ignored. The customer should be shown this valve and told how to shut it off if gas is escaping into the house or any other abnormal situation takes place.

The service outlet should be checked periodically to see if it will still close (many valves in service today have not been shut off in years). Be sure the handwheel is in place and

is accessible. Also examine the stem seal periodically for leakage and replace it if necessary (empty the tank first). The fixed liquid level gauge on the valves will start to show liquid at the 80% level and can be used to check the float gauge reading at that level. If the two don't agree, go by the one that shows the highest filling level until a more thorough inspection and repair can be made.

Fisher™ Type L680 ComboValves are unique because they allow the stem seal to be serviced without first evacuating product from the tank. Closing the valve contains the tank pressure, permitting the bonnet (left-hand thread) and O-ring to be removed and replaced. This greatly reduces the time and cost to repair damaged seals.

The Type L680 can be recognized by the threaded left-hand bonnet with two milled wrench flats that fit a standard 1/2 in. open end wrench, refer to Figure 4.

CAUTION

All other service valves require emptying all pressure from the tank before attempting repairs.

Conclusion

Vehicles have run into tanks, floods have submerged them, and high winds have tipped them over. There have been instances where children playing on tanks have damaged valves, causing accidents. While the LP-Gas dealer is powerless to prevent natural disasters or acts of just plain ignorance, he can establish day-to-day safety practices which will benefit both his business interests and the well being of the customer he serves.

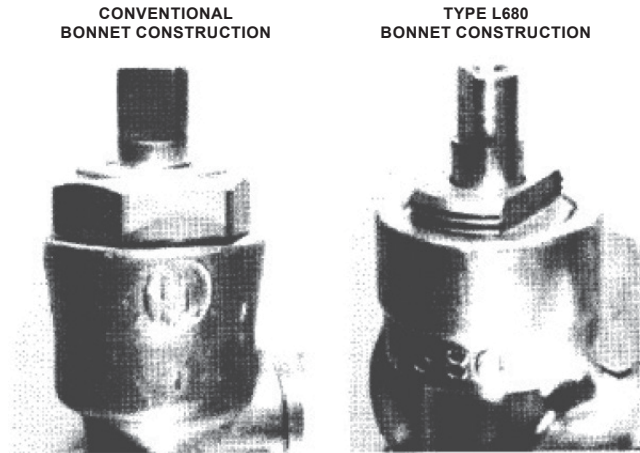

Figure 4. Top view of conventional and Type L680 service valve constructions.

For more information about domestic tank fittings, see the NLPGA Safety Bulletin No. 306-71, "Suggested Regulator and Valve Maintenance." This information, available by writing the NLPGA, comes as a separate bulletin or as a part of the NLPGA Safety Handbook. The various valve manufacturers can also supply product instruction sheets upon request.

 Webadmin.Regulators@emerson.com

 Fisher.com

 Facebook.com/EmersonAutomationSolutions

 LinkedIn.com/company/emerson-automation-solutions

 Twitter.com/emr_automation

Emerson Automation Solutions

Americas

McKinney, Texas 75070 USA
T +1 800 558 5853
+1 972 548 3574

Europe

Bologna 40013, Italy
T +39 051 419 0611

Asia Pacific

Singapore 128461, Singapore
T +65 6777 8211

Middle East and Africa

Dubai, United Arab Emirates
T +971 4 811 8100

D450174T012 © 1977, 2010 Emerson Process Management Regulator Technologies, Inc. All rights reserved. 03/10.
The Emerson logo is a trademark and service mark of Emerson Electric Co. All other marks are the property of their prospective owners. Fisher™ is a mark owned by Fisher Controls International LLC, a business of Emerson Automation Solutions.

The contents of this publication are presented for informational purposes only, and while every effort has been made to ensure their accuracy, they are not to be construed as warranties or guarantees, express or implied, regarding the products or services described herein or their use or applicability. All sales are governed by our terms and conditions, which are available upon request. We reserve the right to modify or improve the designs or specifications of such products at any time without notice.

Emerson Process Management Regulator Technologies, Inc does not assume responsibility for the selection, use or maintenance of any product. Responsibility for proper selection, use and maintenance of any Emerson Process Management Regulator Technologies, Inc. product remains solely with the purchaser.