

# AMS 9420 Wireless Vibration Transmitter

- Accurately monitors vibration and temperature in hard-to-reach locations
- Provides complete vibration data including overall levels, energy bands, high resolution spectra, and waveforms
- Enables three ways to collect spectra: time-based, on-alert, and on-demand
- Emerson solution for Wireless Vibration Monitoring needs when a tethered sensor is needed
- Line Power Adapter option available for high rate data acquisition and different accelerometers
- The ideal complement for the AMS Wireless Vibration Monitor



*The AMS 9420 delivers complete vibration information, including high resolution spectra and waveform, over a self-organizing wireless network for use by operations and maintenance personnel.*

## Overview

The rugged AMS 9420 Wireless Vibration Transmitter is the first device to provide full vibration data over a self-organizing wireless network. It provides rich information about machinery health for both operations and maintenance personnel. Overall vibration, PeakVue, and temperature readings can be easily integrated into any control system or plant historian while diagnostic data can be displayed by AMS Device Manager and AMS Machinery Manager. For advanced diagnostics, high resolution data can be delivered to the AMS Machinery Manager or AMS Machine Works software for trending and analysis.

## Cost-Effective, Reliable Monitoring

The AMS 9420 extends vibration monitoring to an entire array of new applications. While appropriate for most vibration monitoring tasks, it is especially well suited for hard-to-reach locations, such as cooling towers, pumping stations, remote equipment, and hazardous areas.

In general, the AMS 9420 provides an excellent solution for any application that might otherwise involve extensive engineering, cabling, or installation costs. Advanced electronics deliver a high level of accuracy, while the IEC-approved *WirelessHART* standard delivers exceptional reliability.

### Overall Condition in the Control Room

The AMS 9420 delivers information about the overall health of rotating assets directly to the control room via Modbus or OPC. Overall vibration data is a good indicator of shaft problems such as imbalance, misalignment, or mechanical looseness. In contrast, the PeakVue reading provides a reliable measure of impacting on the machine. As the PeakVue level increases, it provides direct indication of a developing problem, such as improper lubrication, bearing fault, or gear defect. Process induced faults, such as pump cavitation, are detected by an increase in both the overall vibration and PeakVue readings.

### Asset Dashboard at your Fingertips

AMS Device Manager generates an asset dashboard based on the output of the AMS 9420. This intuitive interface displays the health of the sensor, the transmitter, and the production asset being monitored – extending the benefits of PlantWeb® to *WirelessHART* devices.



AMS Device Manager uses EDDL technology to create an asset dashboard with clear indication of device and asset status.

# PeakVue™ Technology

### Focus on Impacting for Better Results

Traditionally, vibration data has not been routed to the control room because it required specialized training — and frequently specialized tools — to extract any information from the data. Emerson’s unique PeakVue technology cuts through the complexity of machinery analysis to provide a simple, reliable indication of equipment health via a single trend. PeakVue filters out traditional vibration signals to focus exclusively on impacting, a much better indicator of overall asset health on pumps, fans, motors, or any other type of gearbox or rolling element bearing machine.

PeakVue measurements are easy to interpret and are based on a concept called The Rule of Tens\*. For properly installed and well-lubricated machinery that is not impacting, the PeakVue measurement is at or close to zero. If a problem develops, the PeakVue measurement climbs to 10g. A measurement of

20g indicates a serious problem in the bearing, even though overall vibration levels might not indicate the same. When the measurement exceeds 50g, failure is imminent.

State	Bearing Life Remaining	Vibration (in/sec)	PeakVue (g's)
New	Full	0.15	0
1	<20%	0.15	10
2	<10%	0.15	20
3	<5%	0.16	30
4	<1%	0.18	40
Failure	0%	>0.45	>50+

Typical values for a Horizontal Pump, direct coupled, with machine speed of 900 to 4000 RPM.

PeakVue data provides earlier indication of developing faults in rolling element bearings and gearboxes.

\*Applies to typical process pump with turning speed from 900 to 4000 RPM.

**Diagnostic Data to the Maintenance Office**

AMS Machinery Manager and AMS Machine Works software provides detailed diagnostic data to the maintenance office, including overall values, energy bands, high resolution spectra, and waveforms. Once stored in the AMS database, these measurements deliver the same diagnostic value as comparable readings collected using Emerson’s industry-leading AMS 2140 Machinery Health Analyzer.

AMS software provides advanced analytical tools to trend vibration levels, generate alerts, and diagnose developing faults.

**Information Available When You Need It**

There are now three ways to collect high-resolution spectra or waveforms<sup>(1)</sup>:

- 1) Time-based: Collect readings automatically on a scheduled basis, i.e. once every two weeks.
- 2) On-alert: Collect readings automatically whenever an alert is registered based on either the overall vibration or the PeakVue impacting.
- 3) On-demand: Manually initiate a reading at any point when current diagnostic data is required.

This allows you to quickly and easily access current health information about your rotating assets without leaving your desk.<sup>(1)</sup>

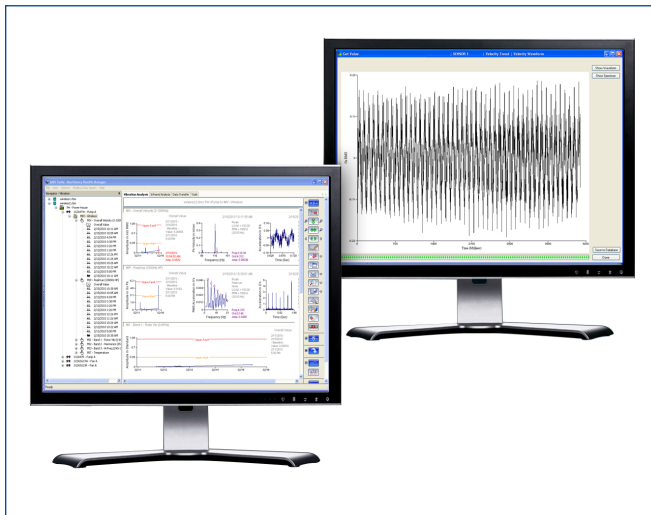

*AMS Machinery Manager and AMS Machine Works software provide advanced analytical tools to trend vibration levels, generate alerts, and diagnose developing faults.*

<sup>1</sup>Not all collection methods are available in all software versions.

**Flexible Configuration Options**

**The Power to Get Things Done**

The AMS 9420 offers flexible power options. For a truly wireless experience, the Blue SmartPower™ Module provides extended operating life in excess of 5 years (actual operating life depends on the device configuration). An optional power adapter is also available that allows the device to be powered by external DC voltage. An AMS 9420 unit can be easily converted in the field from battery operation to line power, and still maintain the units Hazardous Area approvals. This provides the end user with maximum flexibility to configure vibration monitoring to fit any situation.

**Local Indication and Verification**

The optional LCD display provides a local read-out of sensor values and transmitter diagnostics to streamline commissioning and troubleshooting at the device. Local indication of vibration measurements and diagnostics also provides accurate, real-time verification of operating conditions. The LCD display can be rotated to facilitate easy viewing, regardless of the orientation of the transmitter.

**Plan and Manage Wireless Networks**

The AMS Wireless SNAP-ON™ application is a revolutionary tool that enables you to both plan and manage your wireless network. Starting with a scale drawing of the plant, utilize simple click-and-drag functionality to position the gateways and wireless devices. Then the AMS Wireless SNAP-ON application will compare the plan to industry best practices. Recommendations will help you quickly develop a reliable wireless network.

After the devices are installed, the AMS Wireless SNAP-ON application will help you manage the network, providing a graphical overview of the communication paths and network health.

## Wireless Architecture Overview

### Ultimate Simplicity

Built on the IEC 62591 (*WirelessHART*) industrial standard, Emerson's wireless network is completely self-organizing. There is no need to configure communication paths because the Smart Wireless Gateway manages this automatically – including adapting to changing environments. Once the network is established, new devices can be added at any time. Conversely, even if a device is de-commissioned, data reporting from other devices continues uninterrupted over other established paths.

### Easy Installation

The AMS 9420, like all Emerson's Smart Wireless transmitters, is simple to install. As soon as power is applied to the device, it will automatically establish communication with neighboring wireless devices, establish a path to the Gateway, and begin reporting. Each transmitter also has the ability to function as a repeater, relaying data from other devices to extend the network across virtually any size facility or industrial campus.

### Network Stability

The Smart Wireless Gateway connects the wireless network with the host system and data applications like AMS application. The Gateway manages all aspects of the network: executing scheduled readings and accommodating requests for on-demand acquisitions. The Gateway configures the network to minimize power consumption and ensure network stability, while maintaining data reliability well above 99%.

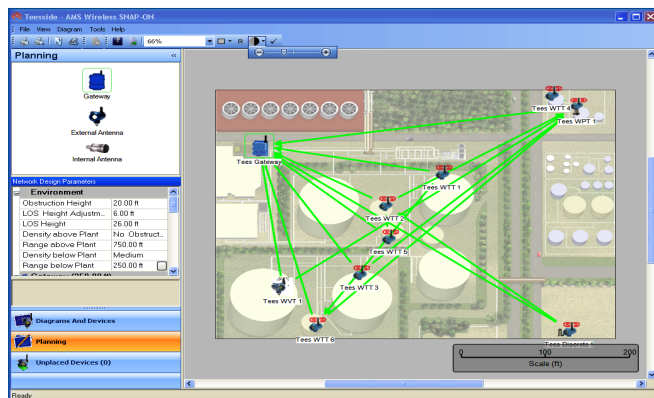

The AMS Wireless SNAP-ON application graphically displays your wireless network.

### Best-in-Class Security

Emerson's multi-layered approach to wireless network security builds on the IEC 62591 standard to ensure that your data stays protected – no matter what. Authentication and verification make certain that only authorized devices can join the network, while 128-bit encryption shields your information. Channel hopping maintains operation, even in challenging environments.

### Emerson's Complete Smart Wireless Solution

Emerson has a complete portfolio of Smart Wireless transmitters for many applications, including temperature, pressure, flow, and level. In addition, the Smart Wireless THUM™ Adapter can enable any HART device to wirelessly transmit measurement and diagnostic information. Emerson wireless devices can be accessed and maintained remotely using the same tools and software as wired devices, leveraging existing practices, training, and maintenance procedures.

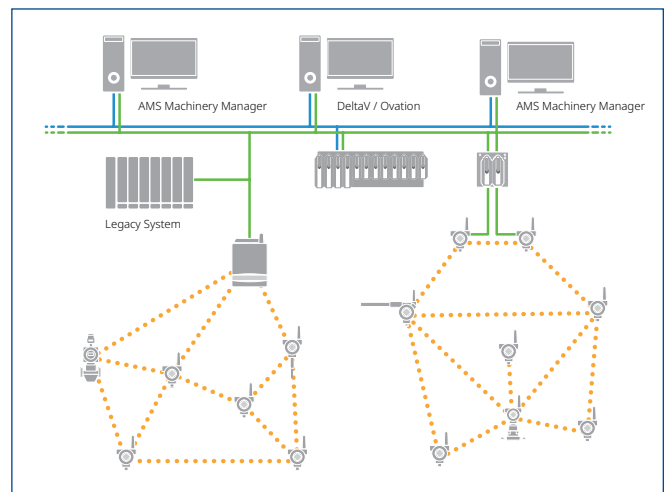

At the heart of Emerson's Smart Wireless solution is the self-organizing network, featuring tight security, infinite configurability, and data reliability that rivals wired systems.

### Seamless Integration to Host Systems

Easily configure and broadcast measurements to Emerson's DeltaV™ and Ovation™ digital automation systems; use Ethernet IP™ to connect to Allen-Bradley® controllers; or apply Modbus or OPC to report data back to most other automation systems and/or data historians.

### Analyze Data in AMS Software

Vibration data from the AMS 9420 can be stored and analyzed in AMS Machinery Manager or AMS Machine Works. The software provides easy data mapping using simple drag-and-drop commands. AMS software combines predictive techniques with comprehensive analysis tools for an accurate assessment of the machinery health in your facility.

### Detailed Reliability Data

Overall vibration indicates when a machine is running rough, while the level of impacting detected by PeakVue signal processing provides the operator with an indication about the presence and severity of a serious defect such as under-lubrication, bearing faults, gear defects, and pump cavitation. Furthermore, once a machine has been flagged, detailed data can be analyzed by a vibration specialist to verify the exact nature of the fault. With the advanced diagnostics in the AMS 9420, you have easy access to all of this critical information.

### High Resolution Waveform

The vibration waveform (shown below) is the basis for all other vibration measurements performed by the AMS 9420. Each waveform is a complex data set of thousands of samples, collected over several seconds of machine operation.

While the acceleration waveform can be helpful in some applications, the PeakVue waveform is indispensable for diagnosing developing bearing and gear defects. Because of their large size, however, waveforms tend to be collected less frequently. Emerson's Smart Wireless solution employs several data compression techniques to extract the information while facilitating easier transmission over the network.

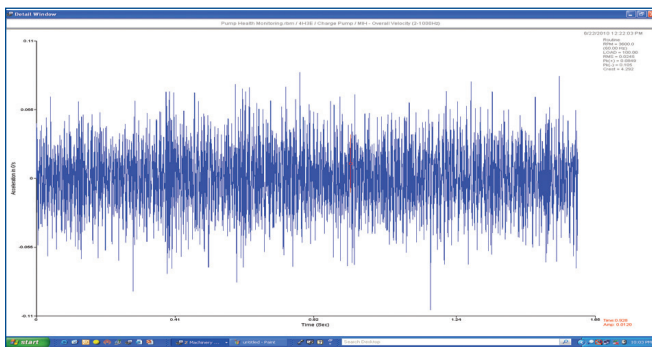

The acceleration waveform contains raw vibration data that allows you to diagnose the health of the asset.

### High Resolution Spectrum

The first compression technique is FFT analysis, which transforms the vibration waveform into a frequency spectrum (shown below). This spectrum not only reduces the file size by over 60%, it also presents the frequency information in a more readable format. The smaller data set accelerates responsiveness of the system while reducing power consumption.

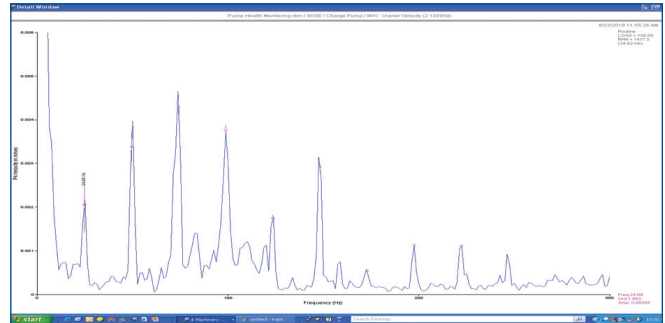

The elevated peaks in this high resolution spectrum provide a clear indication of mechanical looseness on the machine.

### Thumbnail Spectrum

The thumbnail spectrum is derived from the same waveform data. It contains the same frequency and amplitude information as the high resolution spectrum, but the data set has been compressed by an additional 98%. Now it is small enough to transfer over the networking less than a second.

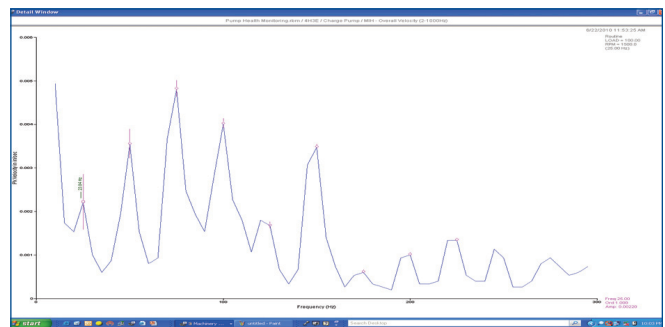

The elevated peaks are still clearly visible in the thumbnail spectrum and indicate the presence of mechanical looseness.

### Energy Bands

As a final data compression technique, the AMS 9420 divides the spectrum into three predetermined energy bands (as shown below). It then calculates the vibration energy within each energy band and passes these values to AMS software for trending and alerts.

Band	Fault Types	Range
1	Rotor Vibration: Imbalance, misalignment (also defects on belt drives)	2–65 Hz
2	Rotor Harmonics: Looseness, electrical faults, blade and vane pass	65–300 Hz
3	High Frequency: Bearing and gear defects, lubrication and cavitation	300–1000 Hz

Energy bands with frequency ranges. Optimized for a 4-pole motor running between 1500 and 1800 RPM. Note: bands are fixed.

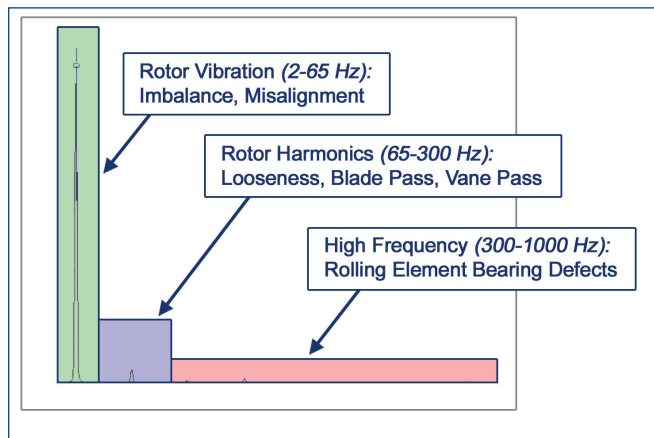

By dividing the spectrum into energy bands, we can isolate frequencies associated with different categories of faults.

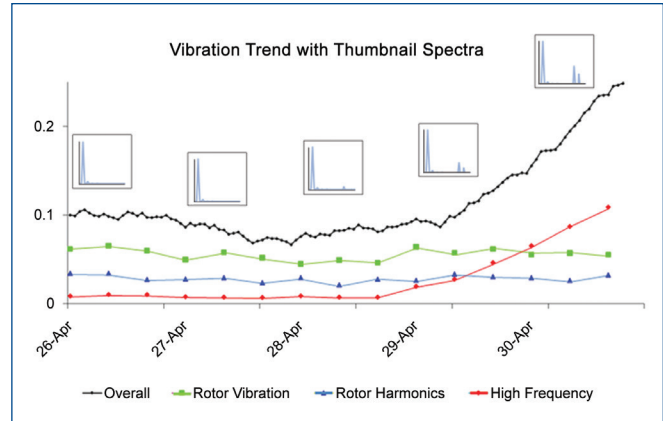

The trend of overall vibration suggests that machine health is deteriorating but without any indication as to the root cause. The trend of the high frequency energy band provides further insight, which can be confirmed by examining the thumbnail spectra.

By trending the values in AMS software and comparing them to appropriate alert levels, it is possible to set up a system of intelligent alerts that not only inform you when the machine condition is deteriorating, but also provide information about the underlying cause of the problem.

The figure illustrates how vibration data can be used to detect and diagnose a developing fault. Based on the increase in overall vibration (black line), an alert would flag the machine as having a potential fault – but with no indication at all about the nature or severity of the fault.

The trend of the three energy bands shows that the readings for rotor vibration (green) and rotor harmonics (blue) are stable, while the readings for high frequency vibration (red) have increased sharply. This would trigger a special alert for the rotating equipment specialist in the AMS software.

Examination of the thumbnail spectra (shown above the trend) confirms that the fault is high frequency in nature. On-demand acquisition of the PeakVue spectrum and waveform then provides conclusive insight into the specific nature of the fault as well as its severity. Using the advanced diagnostics in the AMS 9420 and the AMS software, maintenance personnel can often address and resolve an issue without it ever registering as an alert in the control room.

**Functional Specifications**

Inputs	
Low Power Accelerometer	DC Bias Range: 2 - 3 Vdc DC Input Range: 0 - 5 Vdc AC Input Range: +/- 80 g's peak (784 m/s <sup>2</sup> peak)
Standard ICP Accelerometer (When used with the A9000PS-A Power/Signal Adapter - requires line power)	DC Bias Range: 10-12 Vdc DC Input Range: 0-24 Vdc AC Input Range: +/- 80 g's peak (784 m/s <sup>2</sup> peak) - may vary based on sensor selection
Temperature	DC Input Range: -30° to + 121°C (-22°F to 250°F)
Standard Outputs	
Machinery Health Values	Velocity overall (1 or 2 sensors) PeakVue overall (1 or 2 sensors) Temperature (1 sensor only)
Transmitter Health Values	Ambient temperature Supply voltage Sensor bias voltage (1 or 2 sensors) Multiple internal alerts indicate the status of device health
Advanced Diagnostic Outputs (optional, requires link through an Emerson Smart Wireless gateway device)	
Energy Bands	Rotor vibration (2 - 65 Hz) Rotor harmonics (65 - 300 Hz) High Frequency (300 - 1,000 Hz)
Thumbnail Spectrum	Fmax: 150, 300, 600, or 1,000 Hz
High Resolution Vibration Spectrum	Fmax: 1,000 Hz Resolution: 400 <sup>(2)</sup> , 800 or 1,600 lines Snapshot or Averaged (4 readings)
High Resolution Vibration Waveform	All measurements based on high resolution waveform with 4,096 points
High Resolution PeakVue Spectrum	Bandwidth: 1,000 - 20,000 Hz Fmax: 1,000 Hz Resolution: 1,600 lines Snapshot of impacting on machine
High Resolution PeakVue Waveform	Sampled at 51,200 Hz; High resolution with 4,096 points
Display	
Units	English, metric or SI
Local Display	The optional five-digit integral LCD display provides readout of HART parameters in engineering units (°F, °C, in/sec, mm/sec, g's and m/s <sup>2</sup> ).
	Display updates for each transmission
	Maximum update rate - once per minute
Update Rate	Standard: 1 min to 60 min (User selectable) Power Save: up to 24 hours (User selectable)

(2) Device software version 5.1 or higher required for 400 line spectrum.

Operating Conditions	
Relative Humidity	0 - 95%
Temperature	Storage Temperature: -40°C to 85°C (-40°F to 185°F) Operating Temperature without LCD meter: -40°C to 85°C (-40°F to 185°F) Operating Temperature with LCD display: -20°C to 80°C (-4°F to 176°F)

**Physical Specifications**

Power Options			
SmartPower™ Module	Intrinsically safe Replaceable Lithium-Thionyl Chloride		
External DC-power	Input Voltage: 11 - 28 VDC (when used with A9000Px Power Adapter) Provides unlimited operating life — recommended for applications requiring faster update rates		
Operating Life <sup>(3)</sup>	Values apply to Device Software version 5.020 and higher		
Configuration	1	2	3
Overall Values (min)	30	60	240 <sup>(4)</sup>
Energy Bands (hr)	8	8	8
Spectrum (hr)	24	24	24
High Resolution Waveform & Spectrum (days)	30 (or on alert)	30 (or on alert)	30 (or on alert)
Operating life (years)	1.5 to 3	2 to 4	3 to 6
Materials of Construction			
Enclosure	Housing — Low-copper aluminum (standard) Paint — Polyurethane Cover O-ring — Buna-N		
Terminal Block and Battery Pack	PBT		
Antenna	PBT/PC integrated omni-directional antenna (standard) Optional extended range antenna available in some markets		
Mounting	Vibration sensor must be mounted directly on asset being monitored Transmitter may be mounted up to 100' (30.5 m) away from sensor		
Weight	2 kg (4.6 lbs.) without LCD 2.1 kg (4.7 lbs.) with LCD		
Enclosure Ratings	NEMA 4X / IP66 (when properly installed)		

(3) Operating life with a single SmartPower Module is highly dependent on user configuration. Values shown are for operation at an ambient temperature of 21°C (70°F) as part of a well-formed wireless network. Daily measurements are thumbnail spectra. Continuous exposure to extreme temperatures may significantly reduce operating life. Older revisions exhibit a maximum power module life of 2 years at room temperature with a 54 minute burst rate. Actual results depend on the installation process.

(4) Burst rates over 60 minutes are configured using the "PowerSave" mode.

Performance Specifications			
ElectroMagnetic Compatibility (EMC)	Meets all relevant requirements of EN 61326		
Measurement Accuracy	RMS Velocity <sup>(5)</sup> : +/- 5% from 10 Hz to 800 Hz +/-3 dB from 2 Hz to 1000 Hz  PeakVue Impacting +/- 5% from 2000 Hz to 10 kHz +/- 3 dB from 1000 Hz to 20 Khz  Temperature: +/- 2°C		
Measurement Precision	Vibration: +/- 0.2 dB Temperature: +/- 2°C		
Self Calibration	The analog-to-digital measurement circuitry automatically self-calibrates for each update by comparing the dynamic measurement to internal reference elements		
Vibration Effect	No loss in functionality when tested per the requirements of IEC60770-1 with high vibration level (10 Hz to 10 KHz) and up to 50g acceleration		
RF Output Power (based on maximum device output power of 6.3 mW)	Antenna Type	Max Gain	Max EIRP
	Standard Long-Range	2.0 dBi	10 mW
	Extended Range	4.5 dBi	18 mW

(5) Measurement accuracy is the absolute accuracy of the measurement relative to a known, calibrated excitation for WirelessHART devices. Values shown represent the expected performance operating under steady-state conditions (20°C with no external interference).

### Sensor and Connections

A0394 Sensor Series	
Nominal Sensitivity	25 mV/g (2.5 mV/m/s <sup>2</sup> )
Frequency Range	96 to 600 Kcpm (1.6 to 10 kHz)
Amplitude Range	± 100 g (± 980 m/s <sup>2</sup> )
Broadband Resolution	3 mg rms (0.03 m/s <sup>2</sup> rms)
Settling Time	≤ 2 sec
Temperature Range	-40 to +121°C (-40 to +250°F)
Weight	23 gm (0.81 oz)
Sensor Type	Low profile, side exit integral cable

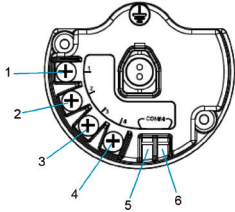
Terminal Block Connections	
Terminal Block	
Configuration 1: Single Vibration Sensor	Connector 1: Red wire Connector 2: White wire Connector 3: Open Connector 4: Black wire
Configuration 2: Single Vibration Sensor with Temperature	Connector 1: Red wire Connector 2: White wire Connector 3: Green wire Connector 4: Black wire
Configuration 3: Two Vibration Sensors	Connector 1: Red wires (2 total) Connector 2: White wire (Sensor 1) Connector 3: White wire (Sensor 2) Connector 4: Black wires (2 total)
HART	Connection Connectors 5 & 6

**Product Certification and Registrations**

General Certifications	
Approved Manufacturing Locations	Emerson Knoxville, Tennessee USA  Benchmark Electronics, Inc. Korat, Thailand
Telecommunication Compliance	2.4 GHz <i>Wireless</i> HART FCC ID: LW2RM2510 IC ID: 2731A-RM2510
ATEX Directive (94/9/EC)	Emerson complies with the ATEX Directive
	Compliant to Electro Magnetic Compatibility (EMC) (2004/108/EC) All Models conforming to the following standards: EN 61326-1
Country	Restriction
Bulgaria	General authorization required for outdoor use and public service
Italy	If used outside of own premises, general authorization is required
Norway	May be restricted in the geographical area within a radius of 20 km from the center of Ny-Alesund
Romania	Use on a secondary basis. Individual license required
Radio and Telecommunications Terminal Equipment Directive (R&TTE) (1999/5/EC)	Emerson complies with the R&TTE Directive
Canadian Standards Association (CSA)	General Safety Standard Certification conforming to the following standards: CSA Std. C22.2 No. 61010-1-4 Safety Requirements for Electrical Equipment for Measurement, Control and Laboratory Use, Part I: General Requirements (Second Edition) ISA S82.02.01 2nd (IEC 61010-1 Mod) Safety Standards for Electrical and Electronic Test, Measuring, Controlling and Related Equipment – General Requirements ANSI/UL Sta. 61010-1 Electrical Equipment for Measurement, Control and Laboratory Use: Part 1 General Requirements (Second Edition)

Hazardous Location Certification <sup>(3)</sup> (Rev 4 and 5)	
US/Canada	Class I, Division 1, Groups C & D Class I, Zone 0 Group IIB, AEx ia IIB T4 Ga Ex ia IIB T4 Ga Class I, Division 2, Groups A, B, C & D Class I, Zone 2 AEx ic IICT4 Gc Ex ic IIC T4 Gc Enclosure Type 4X / IP66
ATEX	II 1 G Ex ia IIB T4 Ga Zone 0 Group IIB II 3 G Ex ic IIC T4 Gc T4 Zone 2 Group IIC
IECEX	Ex ia IIB T4 Ga Ex ic IIC T4 Gc

Intrinsically safe only when used with Emerson power module A0701PBU or 701PBKKF or with A9000Px power adapter and associated barrier. Consult factory for further information on approvals including additional country-specific approvals.

(3) Every effort is made to reflect current status. Consult factory for most recent information.

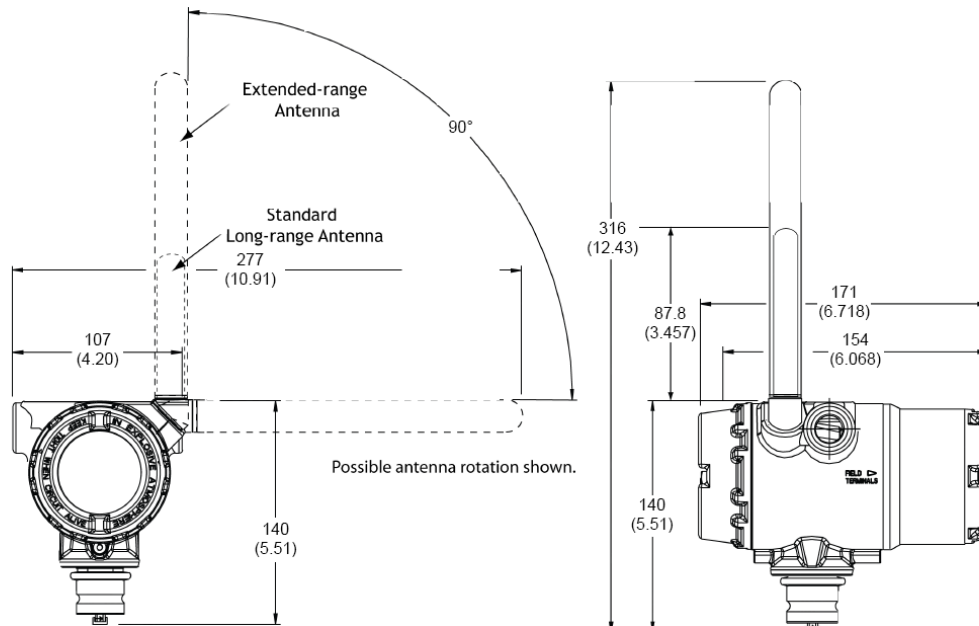

AMS 9420 dimensional drawing with long-range and extended range antennas. Dimensions are in mm (inches).

## Are You Wireless?

As any plant manager will tell you, you can't improve something if you can't measure it. Improved access to information provides the opportunity to reduce operating costs while improving quality, throughput, and availability. Add to that the expanding requirement to certify compliance with new environmental and safety standards. This all points to the need for increased monitoring, yet many managers still believe that the costs outweigh the benefits.

With wired systems, that may have been the case; however, wireless networks remove traditional barriers and redefine the cost equation. A wireless network can substantially reduce engineering, material, and implementation costs, and those cost savings are just the beginning.

Imagine what you can do with the additional information. Wireless technology can reduce – if not eliminate – the “blind spots” in your plant, while empowering mobile workers by providing needed information. The AMS 9420 provides predictive diagnostics for your essential production assets from virtually any location. The result is increased process uptime, improved consistency, and reduced risk of abnormal situations. As more and more plants are turning to wireless solutions, the question is “Are You Wireless?”.



*An AMS 9420 is an easy addition to any existing wireless network.*

©2025, Emerson. All rights reserved.

The Emerson logo is a trademark and service mark of Emerson Electric Co. The AMS logo is a mark of one of the Emerson family of companies. All other marks are the property of their respective owners.

The contents of this publication are presented for informational purposes only, and while diligent efforts were made to ensure their accuracy, they are not to be construed as warranties or guarantees, express or implied, regarding the products or services described herein or their use or applicability. All sales are governed by our terms and conditions, which are available on request. We reserve the right to modify or improve the designs or specifications of our products at any time without notice.

### Contact Us

🌐 [www.emerson.com/contactus](http://www.emerson.com/contactus)