

Batch Historian

- Configuration-free, batch-based data collection
- Reliable data retrieval through data buffering
- Easy-to-use tools for manual or automatic archival of recipe execution and event data
- Supports batch-based analysis
- Supports batch reporting and query tools
- Supports multiple Batch Executives
- Open connectivity using SQL and Web services standards

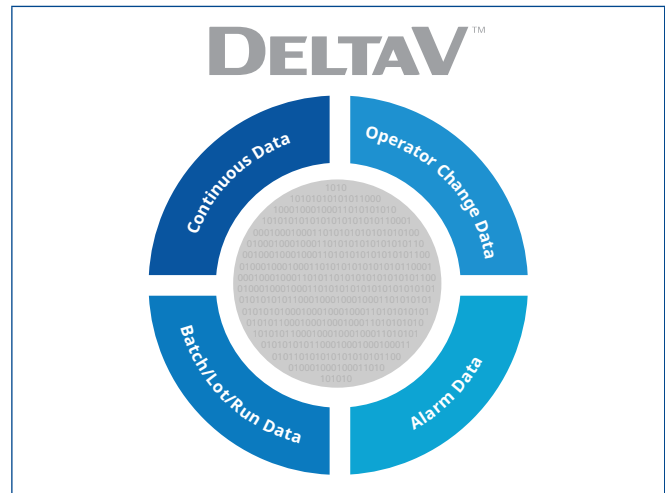

The Batch Historian's recipe execution and event data collection is tightly integrated into the overall data architecture.

Introduction

The Batch Historian is built for batch and was designed from the ground up to meet the needs of operators, production engineers and plant management.

It provides for non-intrusive, automated collection of recipe execution data from the Batch Executive and process event data from the Event Chronicle.

Historical data is viewed graphically using the Batch History View application or one of the other Batch Historian client tools provided with the software. These tools include pre-defined database queries, and an interface for manually or automatically archiving data to another location for mass storage.

Benefits

Configuration-free, Batch-based Data Collection: The Batch Historian is completely non-intrusive and requires no special configuration or support within the process control logic. It works seamlessly with the DeltaV™ Batch Executive and the DeltaV Event Chronicle to collect and store all relevant recipe execution and process event data.

Reliable Data Retrieval Through Data Buffering: The data collection mechanisms implemented within the Batch Historian provide an effective buffering of data in the event that it becomes necessary to take the Batch Historian node offline for maintenance or upgrades.

Easy-to-use Tools for Manual or Automatic Archival of Recipe Execution and Event Data: For longer-term data storage, there are easy-to-use tools that allow users to manually or automatically archive historical data to offline locations, as well as retrieve archived data for analysis using either the Batch History View application or one of the query tools. In addition to automatic data archival, there are also tools to automatically backup the main database and automatically delete the archived data.

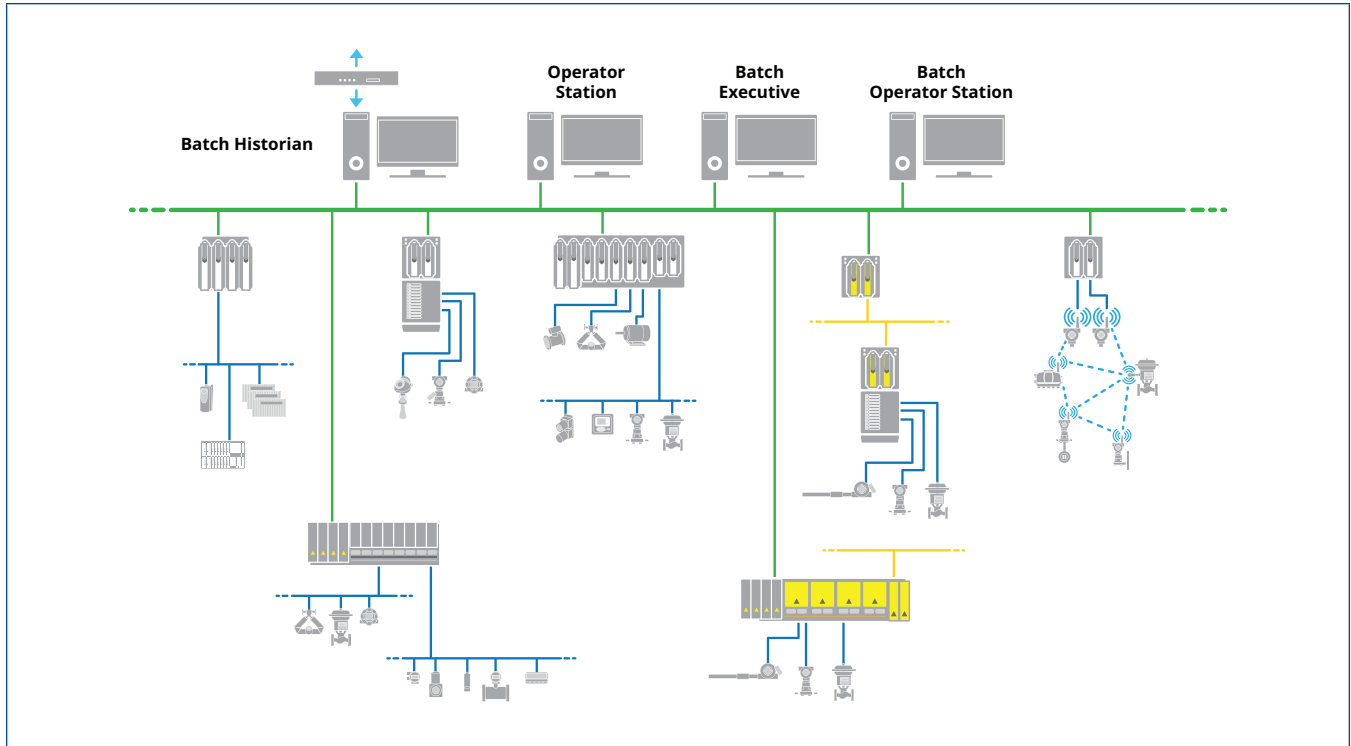

Batch Historian is seamlessly integrated with the DeltaV™ system to offer a complete batch solution.

Supports Batch-based Analysis: Analyzing historical data captured by the Batch Historian is supported from any node on the DeltaV control network using the Batch History View application. Other Batch Historian client tools may be used to retrieve batch-related data for analysis on either a DeltaV Application Station or non-DeltaV node, making it possible to access batch history right from your desktop.

Supports Multiple Batch Executives: With the DeltaV system, you can configure up to four Batch Executives with one Batch Historian per Batch Executive or one Batch Historian for all Batch Executives.

Open Connectivity Using SQL and Web Services

Standards: The DeltaV system is based on open standards, and the Batch Historian is no exception. The Batch Historian is based on the industry standard Microsoft SQL Server database, with documented SQL Views to make external access simple. Batch Historian data is exposed in XML format using the DeltaV History Web Service. The SQL Views and DeltaV History Web Service provide access to all historical data in the Batch Historian database.

Product Description

The Batch Historian uses Microsoft SQL Server as the database technology for storing batch history data generated by the Batch Executive and process alarms and events generated by the Event Chronicle. As you build and execute your recipes, the data is seamlessly collected and read into the Batch Historian's database.

The Batch Historian is completely non-intrusive. There is no need to modify any module or control logic configuration to support the collection of historical batch data. In addition, configuration changes to equipment relationships, such as the deletion of a process unit, have no impact on historical batch data already collected.

The amount of information that can be stored by the Batch Historian is limited only by the amount of disk space available. The user can configure the amount of disk space that the Batch Historian may consume. Additionally, a warning is automatically issued to alert the operator if the remaining available space starts getting low.

Data collected by the Batch Historian can also be archived on a per-batch basis and is catalogued for easy data retrieval. This allows data to be moved offline for longer-term data storage and frees up additional space that has been configured to store data. The data archive procedure may be manual or automatic through the use of the Batch Historian Administration tools. Previously archived data may be restored to the Batch Historian so that it can be accessed by any of the batch client tools, including Batch History View.

Tight integration with the DeltaV security system provides an effective mechanism for controlling access to historical data. Any activities, such as archiving, performed against the Batch Historian's database require the user to have the proper privileges and security access.

Finally, as the Batch Historian continues to be enhanced, tools are available for migrating data from one Batch Historian version to the next in order to preserve existing electronic records.

The Batch Historian Clients

Batch History View: Provides graphical views of batch history based on the S88.01 procedural model. Allows the user to generate batch-based process trends from a single, integrated interface as well as perform batch-to-batch comparisons.

Batch Historian Administration: Windows-based tool for performing administrative functions on the historian's database: manually or automatically archiving data to mass storage, manually or automatically deleting archived data from the main database, automatically backing up data in the main database, and monitoring database size.

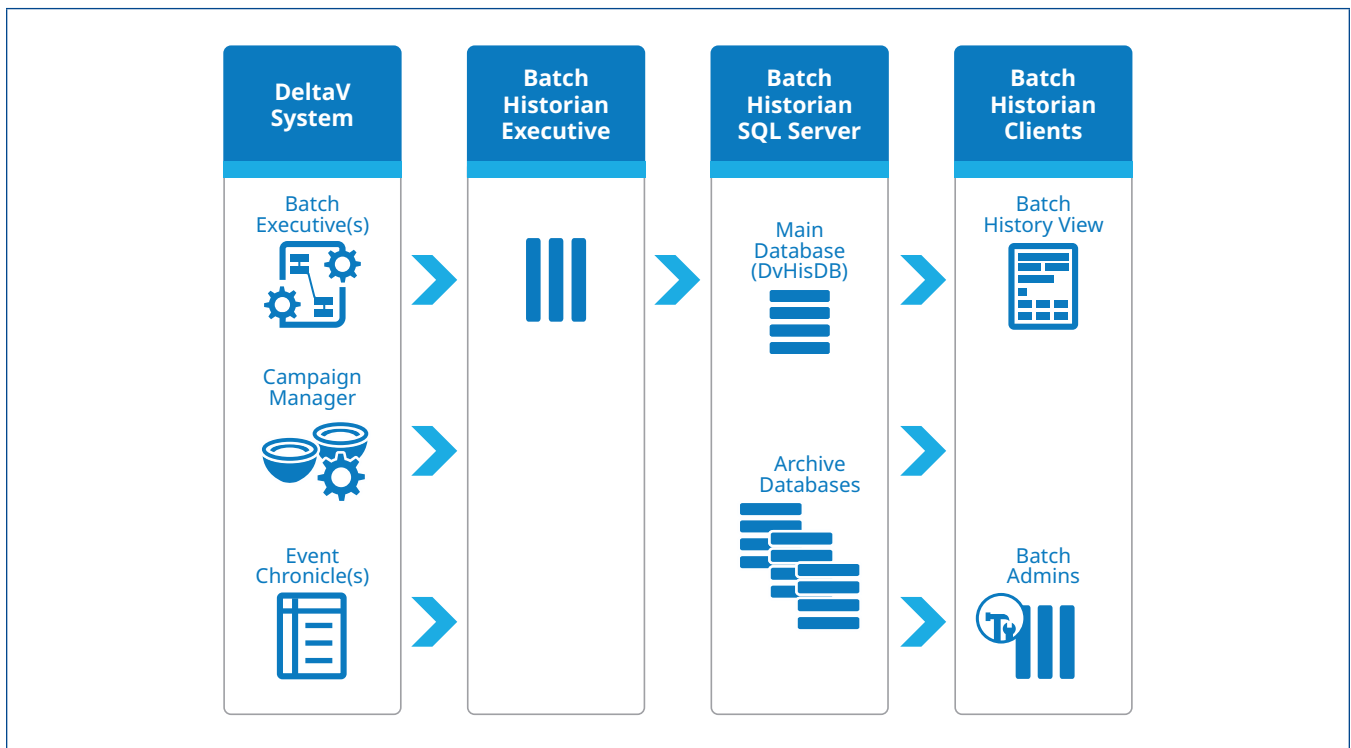

Information flow in the Batch Historian.

Ordering Information

Description	Model Number
DeltaV™ Advanced Batch	VE2248Syyyyy
DeltaV Professional Batch	VE2249Syyyyy

Where yyyy is equal to the total number of class-based Unit Modules configured under Process Cells in the system.

yyyy is available in sizes of 2 Units, 5 Units, 10 Units, 20 Units, 30 Units, 50 Units, 75 Units, 100 Units, 150 Units, 300 Units, and >300 Units.

Related Products

- **DeltaV™ Batch Software Suites.** Basic, Advanced, and Professional Batch software suites provide the DeltaV Batch software needed to operate, historize, and integrate your systems.
- **Advanced Unit Management Software.** Provides class-based Unit Modules and aliasing to make developing unit-relative equipment strategies simple.
- **Recipe Studio.** Powerful yet simple to use application for graphically configuring recipes (with formulas) for successful batch production.
- **Batch Executive.** The batch engine which coordinates all batch processing activity, creates detailed batch history records and schedules recipes and resources.
- **Campaign Manager.** Creates and manages a campaign by specifying the recipe, formula, equipment, and number of batches that are to be run within the campaign. A Service-Oriented Architecture Web Service is available to enable production-scheduling packages to initiate the creation of campaigns in the DeltaV system.
- **Recipe Exchange.** Provides an open, programmatic interface to the DeltaV recipe management system. Recipe Exchange uses a Service-Oriented Architecture Web Service.
- **Batch Redundancy.** Enables redundant DeltaV Batch capabilities for the Batch Executive and Campaign Manager, including automatic switchover to protect your batch operations from disruptions.
- **DeltaV Live.** Emerson's modern, built-for-purpose operator interface. DeltaV Live delivers a high performance HTML5-based operations experience and simplified graphics configuration, all in an intuitive and customizable format with out-of-the-box simplicity.
- **DeltaV Operate.** High performance operator graphics, trends and alarms offered in standard operating layouts and utilizing system-wide built-in security.
- **DeltaV Manufacturing Execution System (MES).** A new class of real-time production management software, provides an easy, flexible, integrated solution that increases plant performance by efficiently managing plant materials and equipment, coordinating production operations, improving quality operations and integrating plant information.
- **Continuous Historian.** Captures up to 250 analog, discrete and text parameters along with their status and stores them for future analysis. Optionally scalable up to 30,250 parameters on the Application Station.
- **History Analysis.** Provides Web-based viewing and analysis of DeltaV batch, continuous and alarm and event data.
- **History View Software Suite.** Monitor your plant's continuous, event and batch data—historically and in real time.
- **DeltaV History Web Service.** Exposes all DeltaV historical data in XML format using Internet-based Web services technology.
- **Event Chronicle.** Captures process, system and user alarms and events and stores them in a Microsoft SQL Server database.

Prerequisites

- One ProfessionalPLUS Station is required for each DeltaV system. Refer to the **ProfessionalPLUS Station Software Suite** Product Data Sheet.
- The Advanced Unit Management software control license is required. Refer to the **Advanced Unit Management Software** Product Data Sheet.
- A minimum of 1 DeltaV Batch Executive is required. Refer to the **Batch Executive** Product Data Sheet for details.
- The DeltaV Advanced or Professional Software suite is required. Please refer to the **DeltaV Batch Software Suites** Product Data Sheet for Details.
- Optimal performance is achieved by running the Batch Historian on a separate DeltaV Application Station. This is recommended, particularly in critical applications. Consult with Emerson before installing the Batch Executive on a workstation other than the Application Station.

©2025, Emerson. All rights reserved.

The Emerson logo is a trademark and service mark of Emerson Electric Co. The DeltaV logo is a mark of one of the Emerson family of companies. All other marks are the property of their respective owners.

The contents of this publication are presented for informational purposes only, and while diligent efforts were made to ensure their accuracy, they are not to be construed as warranties or guarantees, express or implied, regarding the products or services described herein or their use or applicability. All sales are governed by our terms and conditions, which are available on request. We reserve the right to modify or improve the designs or specifications of our products at any time without notice.

Contact Us

www.emerson.com/contactus